





extreme
LEGACY

WE SHARE YOUR PASSION...

OUR CULTURE IS SUSTAINABILITY

 Extreme Legacy is a renowned engineering design and manufacturing firm, specializing in award-winning amusement rides and custom fabrication services. Headquartered in Orlando, Florida, with additional locations across the U.S., we are widely recognized as a leader in creating family-friendly attractions for top-tier destinations and amusement parks worldwide. With thousands of satisfied clients, chances are you've either ridden one of our exhilarating attractions or seen our custom designs in action. We proudly serve industry giants like Six Flags, Disney, Universal, Bluegreen Resorts, Merlin Entertainment, Ferrari World, Holiday Inn, and many more. When it comes to delivering safe, innovative, and thrilling attractions, Extreme Legacy is the go-to expert.

As the top choice for engineering design and fabrication of family coasters and adventure rides, we offer boundless creative possibilities. Our talented design engineers and skilled sales team bring even the most ambitious visions to life. From award-winning rides to expert engineering solutions, we support your creative vision at every step. Our dedication to the amusement industry extends beyond our projects: we actively serve on safety committees, help shape industry standards, and have even held positions on the IAAPA Board of Directors. We do all this because we believe in the industry's future, value safety, and are passionate about creating memorable experiences for families.

Our team wakes up every day eager to tackle the next attraction design or visit a world-class theme park. We're always ready to shape the future of entertainment, but we don't stop there. Innovation, industry expertise, and breakthrough designs are standard in every one of our attractions. We prioritize integrity, honesty, creativity, and the protection of intellectual property to ensure our industry thrives. While others may attempt to follow in our footsteps, we've already moved on. Extreme Legacy is dynamic, always forward-thinking, and committed to providing customers with cutting-edge designs. We make your ideas more real than reality itself. [We believe in inventing forward.](#)

Pictured: Cloud Coaster at Wilderness at the Smokies in Tennessee.

GLOBAL
INDUSTRY
AWARDS

U.S. PATENTS,
GLOBAL PATENTS
& TRADEMARKS

OVER 30
YEARS OF
EXPERIENCE

CUSTOMERS
WORLDWIDE



WHAT WE DO, WHY WE DO IT...

We co-create with the best customers in the world to provide to the best parks in the world. We are the ultimate providers in engineering design & family-friendly attractions. Let us break it down for you:

03 - 11

ENGINEERING DESIGN

Brilliant engineers. Adrenaline seeking designers.

12 - 40

FAMILY SUSPENDED COASTERS

3-Time IAAPA award winning coaster and voted top 10 attraction by USA Today.

- CLOUD COASTER 13 - 22
- SKY TAG 23 - 29
- CLOUD COASTER STORM 30 - 34
- SURFIN TSUNAMI 35 - 40

41 - 47

ADVENTURE PARKS

Live, breathe and experience the High-Action Adventure.

48 - 54

FLY WIRE ZIPLINES & AUTO-ZIP

Soar at great heights on the IAAPA award winning zipline.

55 - 57

EXTREME AIR

Jump in the air on this 2-time award winning attraction.

58 - 61

PARKOUR AROUND

Go from zero to hero in just seconds.

62 - 75

ROCK CLIMBING WALLS

You ready to rock? We hope so.

- GEOWALL 62 - 65
- GEOWALL ARCADE 66 - 69
- EXTREME WALLS 70 - 71
- SOLID SYSTEM 72 - 74
- AUTO-BELAY 75

76 - 93

MOBILE ADVENTURE

Adventure on the go.

94 - 100

FLX SHADE SYSTEMS

Easy aid to shade.

101 - 105

FUTURE ATTRACTIONS

A snapshot on what is next.

ENGINEERING DESIGN

Brilliant engineers. Adrenaline seeking designers. We're the ultimate left brain/right brain company.



WE LEAD THE INDUSTRY. SIMPLICITY, QUALITY & INNOVATION ARE STANDARD IN ALL OF OUR DESIGNS.



We're Inventing Forward:

Our team of mechanical and aeronautical engineers holds degrees from prestigious institutions around the world, with a combined experience of over 60 years in engineering design. We have worked with leading companies such as Hughes Aircraft, American Hospital Supply, and Hewlett-Packard. Additionally, we've provided consultation services for renowned companies including Ferrari World, NASA, Disney, Universal, Merlin Entertainments, and many others.



DESIGNS ARE ENGINEERED, TESTED & BUILT IN AMERICA.

Our state of the art business, with state of the art people.

Extreme Legacy is recognized as the industry leader, supporting amusement ride manufacturers and A&E firms, with creative, turnkey product development solutions and manufacturing support. All of Extreme Legacy's designs meet industry standards such as CE, ASTM, EU, TUV and can meet CSEI. Our design firm has over 45 patents, such as magnetic braking solutions on suspended roller coasters, aerospace designs on fighter jets, automatic delay devices to decelerating components used on funiculars, trams and ziplines.



Extreme Legacy's headquarters is in Orlando, Florida. Our state-of-the-art production and R&D facility is also located in the U.S. The production plant is head by AWS certified welders with additional experts in manufacturing, horizontal integration and assembly. Our production facility is operated by a rigorous quality control process and driven by a computer driven MRP system for managing tooling, assembly parts and hardware. Advanced testing methods are applied to all of the products and parts assembled in our factory.



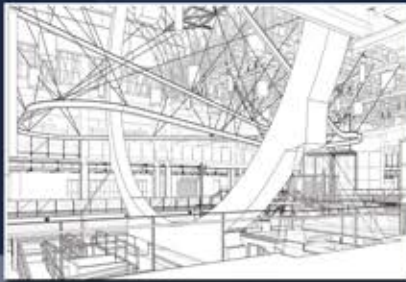

WE BREAK THE MOLD

Our creative team works non-stop to dream up innovative and ground breaking products that all meet or exceed engineering quality standards so customers can oversee operations with confidence. Using state-of-the materials and cutting-edge technology, Extreme Legacy delivers reliable, top-quality solutions, empowering customers to manage operations with confidence while staying within their budget and timeline.

WHAT WE OFFER:



MECHANICAL ENGINEERING

With over 4 decades of expertise in mechanical engineering and design, we can assure you the product will be built correctly, safe and precise the first time. Engineering is in our DNA. We live, breath and build creative solutions that are either a first in the industry or a major improvement to an existing product. We got you covered.



ANALYSIS

We don't just build something, we test it! The most crucial step in all of our designs is detailed analysis. We make sure analysis is applied to all product designs prior to production. Our expertise in analysis procedures provides the right design for the right job. Each analysis we complete will include: Thermal/Flow, Structural, Tolerance & EMI/RFI containment.



ELECTRICAL ENGINEERING

We partner with some of the best electrical engineers in the field. Many of our product designs involve electrical hardware development, software development and electrical testing. If your product design requires electrical engineering we can manage this for you.



PROTOTYPING

Quick prototyping allows our customers to ensure the function, design and aesthetics of their product design. We can offer a full scale prototype to a scaled 3D printed or CNC first article. We work with some of the latest technologies available in providing accurate prototypes that help our customers visualize their reality.



PRODUCTION

Our production facility can accommodate high-volume, precision products and parts at competitive rates. From transport trailers for expensive airplanes, roller coasters, tractor attachments, custom brackets, support columns to funiculars, we can build it all! We can easily ship anywhere in the world, being near the largest ports in the United States. With our AWS welders, expert assembly team, process engineers and project managers we can deliver the best products in the world in a timely manner.

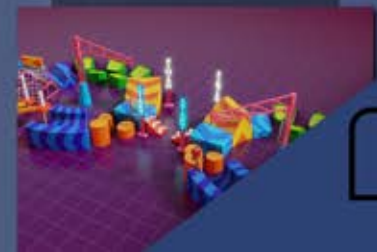
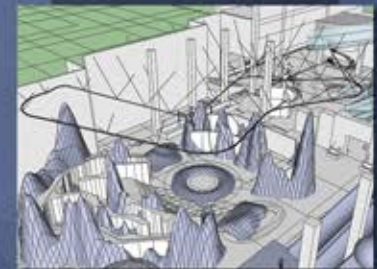

SOME OF OUR AWESOME WORK...

We design, value engineer, test and build products forward.



DOLLYWOOD'S TREE PROJECT

The creative team from Life Formations, an industry leader in theming and animatronics, partnered with team members at Extreme Legacy to build Dollywood's latest expansion project at the park, Wildwood Grove. Our team turnkeyed the entire steel structure, providing the structural engineering, design, P.E. stamping, project management and fabrication of the massive structure. The structure had to also meet CWS and D1.1 weld standards. Dollywood's "Tree of Life" measured at over 50 feet tall and 50 feet wide. The tree had to include hundreds of custom designed branches that would be easily clocked and bolted to the base. Each branch had to hold over 650 lighted butterflies, including over 9,000 leaves.



TRANS STUDIO BALI'S STUNT SHOW MINE CART

Team members from Extreme Legacy partnered with The Producers Group, a premier provider of production and design services for destination attractions worldwide, on their Trans Studio Bali project. The Producers Group was in need of a custom gag for Trans Studio Bali's anchor stunt show. The show required a custom mine cart on a coaster track that allowed stuntmen to easily control the speeds of the carts while battling in between scenes. The cart system also had to disappear under the stage and then easily reappear for the next act. Our team custom built the coaster track, including a self-supporting structure to not entirely rely on the building's slab. The carts were also designed to use eddy current braking that could easily be tuned by the rider.



Illustrations by: TPG



Illustrations by: TPG



SOME OF OUR AWESOME WORK...

We design, value engineer, test and build products forward.



UNIVERSAL'S SUSPENSION BRIDGES

Team members from Extreme Legacy were hired by Universal to design and fabricate their signature suspension bridges at the famous waterpark, Volcano Bay. The bridges had to be self-supporting, provide additional support to the existing columns and also have the feel and look of worn, wooden planks when walking across. The bridges had to meet Universal's strict standards, including CWI, NDT and P.E. stamping.



UNIVERSAL'S ROLLER COASTER ANCHORS

Our team provided roller coaster anchors, for several other roller coaster manufacturers, used at various Universal parks. Each anchor was precision made, tested and built to each roller coaster manufacturer's standards.



SOME OF OUR AWESOME WORK...

We design, value engineer, test and build products forward.



SAN DIEGO SYMPHONY

Team members from Extreme Legacy were subcontracted to help on the construction of the San Diego Symphony, located at the Port of San Diego. The San Diego Symphony is a top-notch stage located at the scenic spot, Embarcadero Marina Park South, overlooking the waterfront. Our team provided part of the steel support structures, holding up the beautiful arching domes. Engineers from Extreme Legacy also value engineered the steel beams to support high wind loads experienced in the harbor, including providing special coatings to prevent corrosion. Overall aesthetics were enhanced, from the original design, with precision laser cut tension mounts to support the hanging canvas. These mounts would be visible and exposed to the general public. The mounts were redesigned to exceed the overall look and feel of the symphony's modern design while still maintaining structural integrity and wind load requirements.



STTA SOLANO TRANSPORT AUTHORITY BUILDING

Our team was subcontracted to design and fabricate façade structures for Solano Department Authority's new headquarters in Suisun City, California. Extreme Legacy's engineering team value engineered the façade structure to be built cost effectively, providing drastic improvements on the overall aesthetics to the building's modern design. The façade was carefully designed and engineered to fit seamlessly with the exterior portion of the new headquarters, enhancing the final structure. Extreme Legacy designed the façade structure to meet ASTM building code standards, including providing a P.E. on the improved design.



SOME OF OUR AWESOME WORK...

We design, value engineer, test and build products forward.



SILVER DOLLAR CITY'S FLUME RIDE

Our team was asked to partner with RES to help engineer and fabricate Silver Dollar City's flume ride attraction that opened in 2020 called "Mystic River Falls." The famous park set in Branson, Missouri relied on several suppliers, with Extreme Legacy building the flume channels and other precision ride components. Our engineering team was able to value engineer the original parts, saving the client both on fabrication costs and delivery timelines. Each part was fabricated through precision laser machines and finished with our certified welders. All channels were then special coated, per Silver Dollar City's requirements to last the harsh environment underwater.



○ Z M O Y ROPES COURSE HEXI POD

Ozmoy, an industry leader in steel ropes courses, partnered with Extreme Legacy to build precision ropes course platforms and railings. Ozmoy's patented ropes course design utilizing a Hexi-Pod configuration, providing a modular and large adventure course platform. Our team enhanced and value engineered the design of the platforms, saving the client approximately 20% on production costs. Fabrication, coatings, redesign and testing were provided by Extreme Legacy.



SOME OF OUR AWESOME WORK...

We design, value engineer, test and build products forward.



ICON'S A5 AMPHIBIOUS TRANSPORT SYSTEM

Team members from Extreme Legacy were hired by Icon Aviation to design and build their amphibious transport system for the A5 aircraft. The design had to safely load and also lower the plane on ground or in water. Our team prototype tested, engineered and fabricated the transport system to have the same look and feel as the A5 aircraft. The system had to be corrosion proof and include submersible hydraulics, which would guide the aircraft on and off the trailer. The control system could also be operated by a smartphone App.



FROM COASTER COLUMNS, FACADES TO STRUCTURES

Extreme Legacy has worked with various suppliers in multiple industries across the globe. From roller coaster columns, queuing gates, facades to precision commercial equipment, we got you covered. Our team of engineers, certified welders and project managers specialize in value engineering your product, parts and/or components. We strive on providing the best value, quality and on time results in the industry.

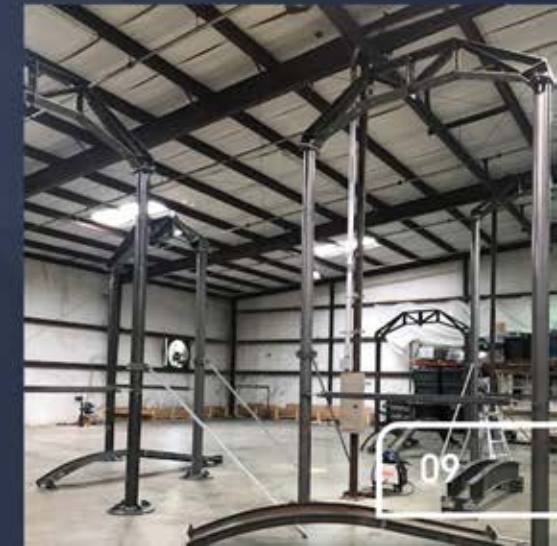

SOME OF OUR AWESOME WORK...

We design, value engineer, test and build products forward.



FIRST COMMERCIAL GOLF BALL CANNON LAUNCHER

Extreme Legacy teamed up with Atomic Golf to create cutting-edge golf ball-launching cannons, offering an exciting new way for guests of all ages to launch golf balls onto the driving range. Our design team has developed two cannons equipped with controlled compressed air tanks and onboard computer systems. These systems can propel golf balls at speeds over 100 MPH, reaching distances of up to 200 yards. Once the spring-loaded handles are pulled back, the cannons automatically charge their air cells, with a green light signaling they're ready to fire. For added precision, guests can aim using the built-in scope. The cannons became available to the public in March 2024.



TREASURE HUNT THE RIDE

MOTION FLOOR FOR TREASURE HUNT: THE RIDE

Commissioned by Sally Dark Rides and Daniels Wood Land to design and construct a motion floor effect for the pre-show of the award-winning attraction, Treasure Hunt: The Ride, located in Monterey, California. This motion floor became a key feature of the pre-show experience, simulating a journey through a themed mineshaft. Developed by team members at Extreme Legacy, the floor was designed to vibrate and shift, including a synchronized hidden screen that unveiled an intricate set featuring animatronics. The motion floor was also built to accommodate large groups, making it easier to manage guests as they queued for the dark ride vehicles. Treasure Hunt: The Ride garnered significant acclaim, earning a prestigious Brass Ring award at the 2023 IAAPA Expo.



SOME OF OUR AWESOME WORK...

We design, value engineer, test and build products forward.



STEEL STRUCTURE FOR PIRATE SHIP

LF Studios, a global leader in scenic fabrication and animatronics, has partnered with Extreme Legacy, a company known for its top-notch fabrication and engineering design, to create a striking steel substructure for LF Studios' newest venture: a pirate ship for Skiparr's Putt. The majestic pirate ship, complete with a fearsome kraken, has been carefully crafted in multiple sections and installed over 20 feet above the main entrance of the mini-golf facility. Located on "The Street of Fun At The Falls," this colossal attraction is poised to mesmerize thousands of visitors from around the world.



CATERPILLAR STRUCTURE FOR CHILDREN'S HOSPITAL

After completing the initial engineering design for Storyland Studios, Bethany Children's Health Center collaborated further with Extreme Legacy to bring this extraordinary project to life. The caterpillar structure's vibrant colors will be visible from afar along Route 66 and will feature interactive LED lights, which will dance and illuminate the structure at night. Project is scheduled to be completed in 2025.



FOUR WAYS TO FLY

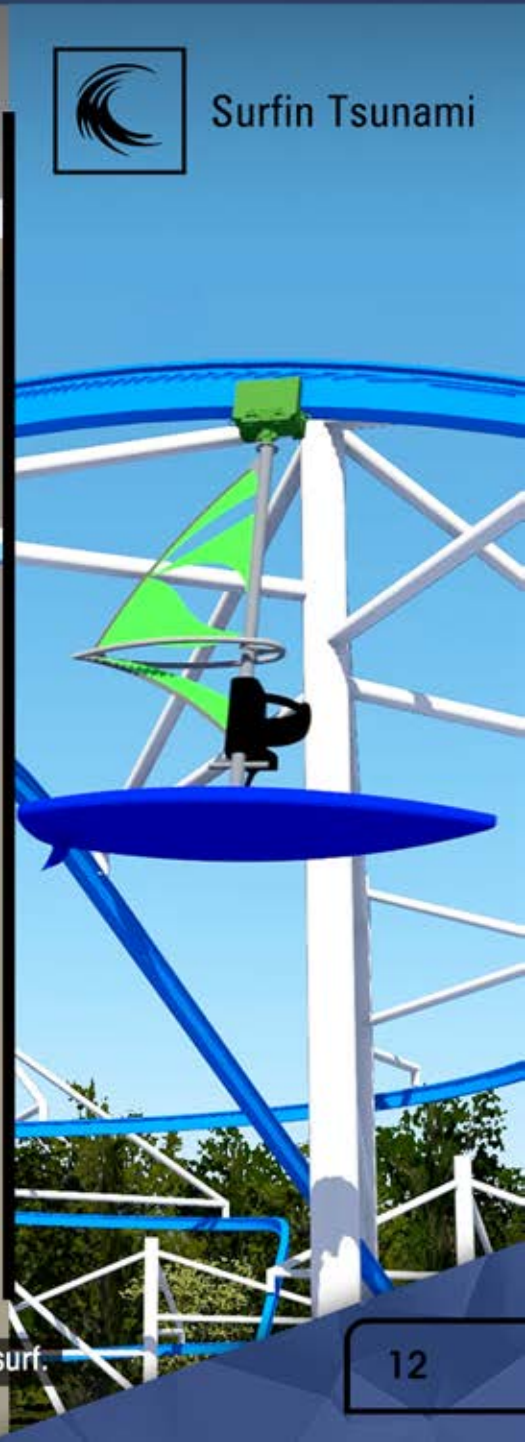
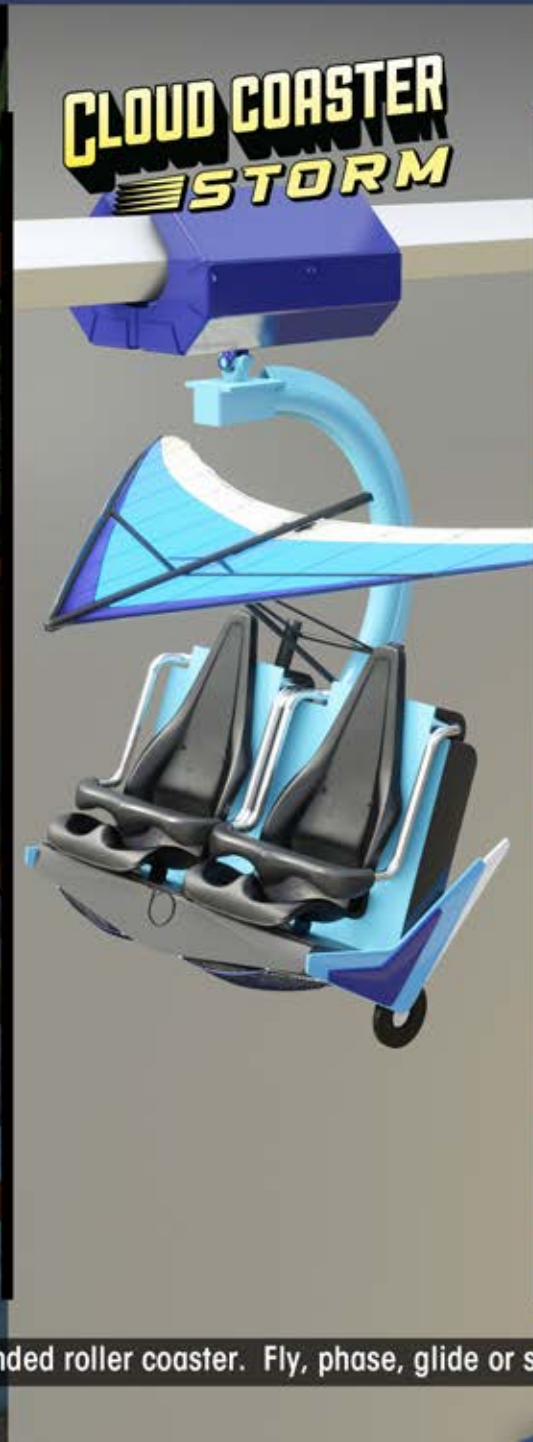

The only 3-time, award winning family suspended roller coaster. Fly, phase, glide or surf.

CLOUD COASTER™



The suspended family coaster, Cloud Coaster, was awarded Best Major Theme Park Ride by IAAPA, top 10 best new attraction by USA Today and top 15 most anticipated coasters by Coaster101.

CLOUD COASTER™

EXPERIENCE THE SENSATION OF FLYING AND ROCKETING DOWN A SUSPENDED FAMILY COASTER.
3-TIME AWARDED ATTRACTION BY IAAPA.

ABOUT THE CLOUD COASTER™

Experience the family-friendly, award winning roller coaster of a lifetime. U.S. & International Patents.



The Cloud Coaster™ is the only three-time award winning family-friendly roller coaster on the market. Experience fast, controlled and safe speeds that give you the sensation of flying and rocketing down a roller coaster. With smooth turns, launching around structures and automated lift hills and this family-friendly attraction brings in the fun.

The Cloud Coaster™ provides endless possibilities, offering any desired length, custom themes or track layouts. We also offer over 65 standard layouts with each version providing a unique ride experience, budget and throughput. This coaster can be designed to fit around existing structures, be designed to fit seamlessly indoors and designed to fit within existing attractions at an amusement park, waterpark or resort. This family coaster can also be configured to achieve fast cycle times, supporting parks in need of large capacities.

Want to go up hill? No problem. Want to start high in the air? No problem. Need a high-capacity product? No problem. Problems? No problem. We got it handled.



MEDIA RESPONSE

"The roller coaster uses frictionless, high-load, magnetic brakes. This marks the first time magnetic brakes have been used on this type of application. The coaster can work in any temperature and in both dry and rainy conditions."

- Funworld Magazine

HOW OUR DESIGN PROCESS WORKS



You provide us with your space and we will fill it with possibilities. We make the Cloud Coaster™ design process exciting by co-creating the attraction with you. We listen to your needs, your goals and help you create a coaster that is injected with pure excitement. The Cloud Coaster™ is both creativity and family-friendly thrills in one fantastic ride. We believe that fun is what inspires creativity and creativity is what makes great attractions.

In just four simple steps we turn allocated space into reality. Each step works towards a final solution that is tailored to meet your needs. We believe in a turnkey process, so let us do the heavy lifting. From sales to engineering, we all work in sync to ensure you with the best possible family-friendly coaster on the market.

Here are how the 4 steps work:

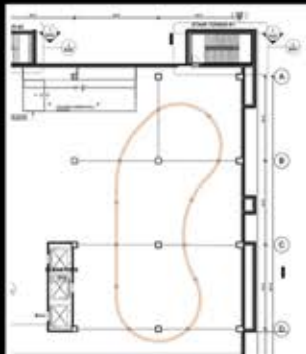

ONE
SPACE LAYOUT

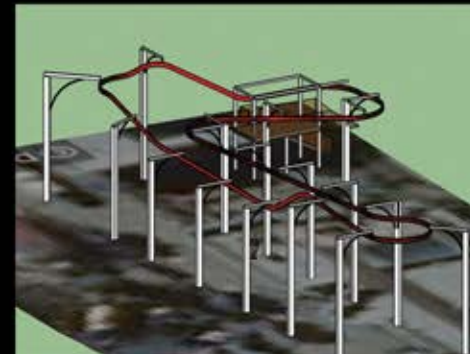

TWO
RENDERINGS



THREE
ENGINEERING



FOUR
REALITY

OUR FEATURES ARE FOCUSED ON YOU

The anatomy of the Cloud Coaster™

Pictured:
Mega Parc in Quebec, Canada. First roller coaster to go through a Ferris Wheel in North America.

1. Loading Platform



The Cloud Coaster™ uses a load/unload platform, where riders start and finish, controlling the que lines. The loading platform is typically where the first lift hill resides and where all the operating controls are located, allowing a single operator to control the Cloud Coaster™. Low power requirements make this a breeze on electrical set up. The coaster is ecofriendly, operating on as little as 15 AMPS (a hair dryer). A battery backup is installed on the lift motor, allowing up to 10 cycles before powering down during a power outage.

2. Go Up Hill



The Cloud Coaster™ uses lift systems and to control speeds, create block zones throughout the roller coaster track and manage cycle times. The lift systems also control the distance between each rider, ultimately allowing several ride vehicles on the track at one time. The lift hill system has a built in safety locking mechanism, providing redundancy while in operation.

3. Eddy Current Braking



The Cloud Coaster™ features high-load capacity magnetic brakes, our patent pending "M.B.S.™" braking technology, on the trolleys to slow down riders safely. No power, no friction or brake pads are required to operate the brakes. The M.B.S.™ works all the time in any weather condition or environment.

4. Ride Vehicles



The Cloud Coaster™ ride vehicle allows riders as short at 40 inches with a maximum weight capacity of 250 pounds (101.6 cm height to 113 kg max weight). The coaster vehicles are designed to secure riders quickly, easy and safe. These ride vehicles increase cycle times! A wide variety of attachments are also available. Ride together in a tandem seat, standup surfboard or even ride facing each other! Each choice will provide you a unique suspended roller coaster experience. Custom theming also available.

THE CLOUD COASTER™ CART

The anatomy of the roller coaster cart

M.B.S.™ TECHNOLOGY

The M.B.S.™, on the Cloud Coaster's™ trolley, is an integral part of our passive magnetic braking device. This patent pending design uses magnetic braking, requiring no power, with a lifespan of 300 years! Our rare earth magnets are one-of-a-kind, and the first in the industry, to use Eddy Current principals applied to a coaster cart's trolley. The M.B.S.™ is also ecofriendly, saving on expensive power requirements needed for other type of braking methods. The M.B.S.™ can be adjusted to apply strong or as little braking force as necessary.

STEEL CART BAR

The ASTM rated steel bar is used to mount the coaster's seat and restraint system. This steel cart bar has precision drilled holes providing aerospace aesthetics and weight reduction. Multiple colors options available.

ERGONOMIC SEAT DESIGN

The coaster seat is custom sculpted, to fit most body types, providing the maximum comfort during use. Seat is made from high-density, closed cell foam, with an extruded fiberglass backing. The coaster seat is extremely easy to sanitize and wipe down. Multiple color options are available.

HANDLEBARS

The cart's handlebars allow the rider to comfortably hold onto the sides of the seat. Handlebars provide the sensation of security, especially for those who don't want to hold their hands out during the Cloud Coaster™ experience. The handlebars are also designed to provide operators an easy way to control the carts during the end and start of the attraction.

PRECISION WHEELS

Extreme Legacy's machined coaster wheels utilize a proprietary technology making each wheelset extremely fast, durable and ridged to last plenty of cycles. This technology is designed to freely move carts at rated loads with complete ease. Our wheels also use a urethane polymer designed to provide an extremely smooth coaster experience. No aftermarket wheels come close to these precision beauties!

SWIVEL WITH SWAY CONTROL

The precision machined swivel safely attaches the coaster trolley to the Cloud Coaster's™ cart. The swivel also provides a dampening feature, for rider comfort, creating the real sensation of flying and floating through the air.

ELECTRONIC SAFETY RELEASE

The electronic safety release provides redundancy in the overall safety lock of the lap bar. It is powered by lithium, rechargeable batteries with easy connectivity for recharging. This safety release is located on the backside of the chair, preventing ease of access to riders.

LOCKING LAP BAR

The locking lap bar provides Infinite adjustments for rider comfort. The electronic release applies hydropneumatics in the riding position. The hydraulic locking unit (HLU) is specifically designed for passenger restraint systems. The HLU is lab tested, easy to use and has proven reliability with high-cycle counts. This device exceeds all international safety standards.

HIGHLIGHTED CLOUD COASTER™ LOCATIONS

Here are a few exciting coaster projects

MARGARTAVILLE
Resort
BILOXI, MS



 **ROCKIN' JUMP**
THE ULTIMATE TRAMPOLINE PARK



 **ZAVA ZONE**



HIGHLIGHTED CLOUD COASTER™ LOCATIONS

Here are a few exciting coaster projects

MÉGA PARC
Le plus important parc d'attractions intérieur au Québec



HIGHLIGHTED CLOUD COASTER™ LOCATIONS

Here are a few exciting coaster projects



HIGHLIGHTED CLOUD COASTER™ LOCATIONS

Here are a few exciting coaster projects



HIGHLIGHTED CLOUD COASTER™ LOCATIONS

Here are a few exciting coaster projects



NOW OPEN



RICHLAND CHAMBERS

COMING SOON

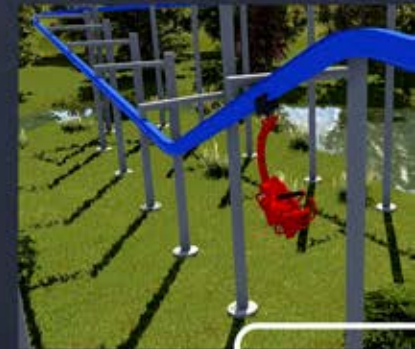



SKY TAG

Laser Tag In The Sky



Now you can laser tag in the sky on the all-new Sky Tag!
Sky tag is a family-friendly, modular coaster attraction for family entertainment centers.



This is a family-friendly, action packed, suspended dark ride. Experience an interactive attraction, full of suspense and unlimited possibilities. Guests can soar above creative environments while being suspended on an roller coaster. Optional laser tag can easily transform the award winning Cloud Coaster™ into the all-new Sky Tag™. Sky Tag™ can fully immerse guests into creative worlds, while playing laser tag in the sky!

SMALL FOOTPRINT SUSPENDED LASER TAG COASTER

Budget-friendly suspended dark ride that packs a mighty punch...

The Sky Tag's™ track and cart design are engineered to be low cost, allowing more opportunities to invest towards theming and interactive laser tag solutions on the attraction. This ride vehicle platform's goal is to offer a modular, high-capacity and affordable interactive dark ride solution. With space, cost and capacity being crucial, the Sky Tag™ is perfect for FECs to amusement parks with a limited budget. This suspended dark ride provides endless possibilities, offering any desired length, custom theme or track layout.

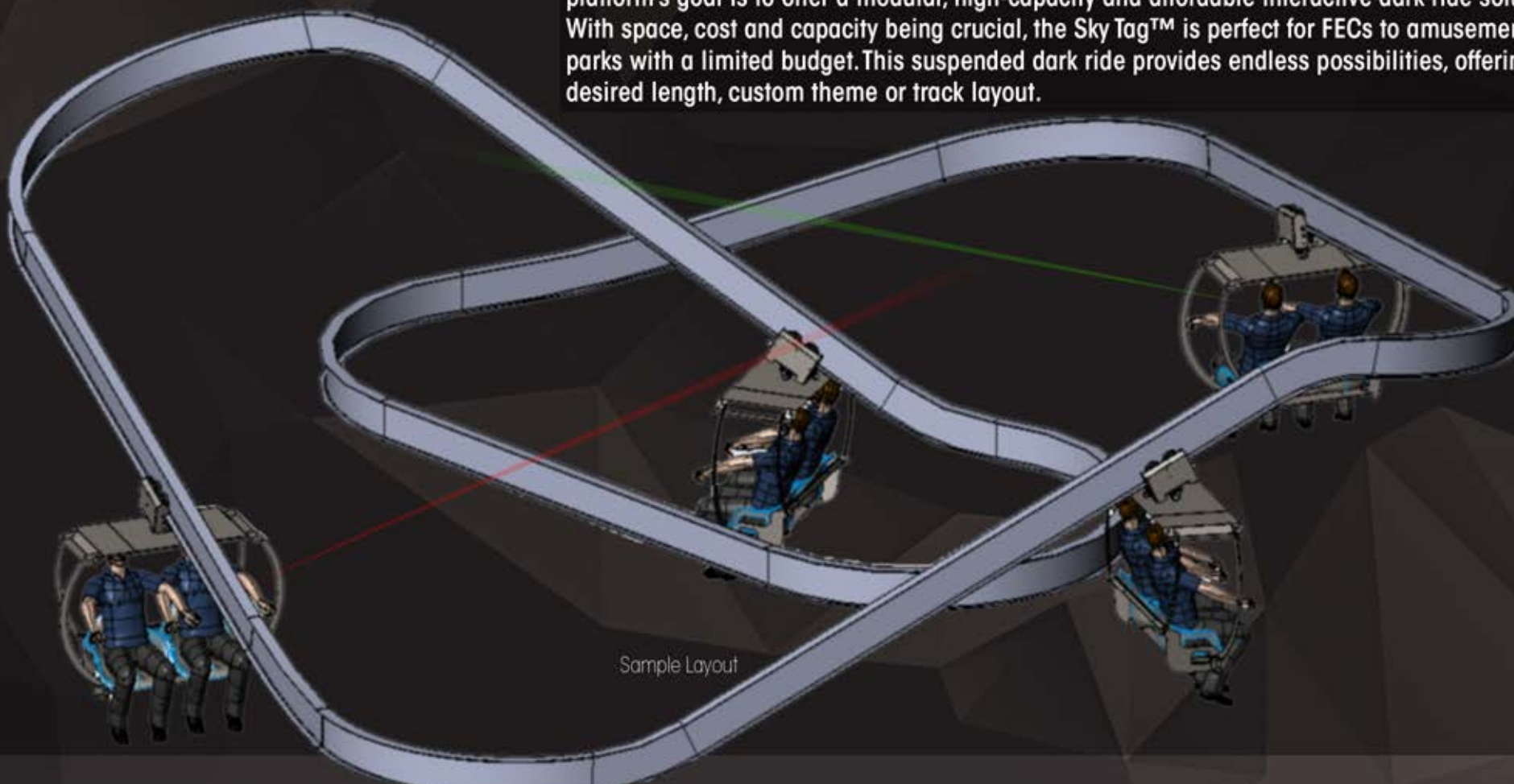

COMPACT DARK RIDE LAYOUT

This exciting track configuration will soar guests high in the sky in complete darkness providing unexpected turns, drops and sudden stops all in just a 40 x 40 footprint (1600 SQ FT). Phasers are integrated into the ride vehicles, creating an exciting and interactive dark ride experience. Riders will soar above obstacles below, on approximately 171 linear feet of track. The Sky Tag will launch 4, side-by-side vehicles, suspended on the coaster's track. This attraction will provide 120 seconds of thrills, while riders circle the track twice, providing a traveling distance of 342 feet. Capacity can reach in the upwards of 240 people per hour!

SMALL FOOTPRINT SUSPENDED LASER TAG COASTER

Budget-friendly suspended dark ride that packs a mighty punch...

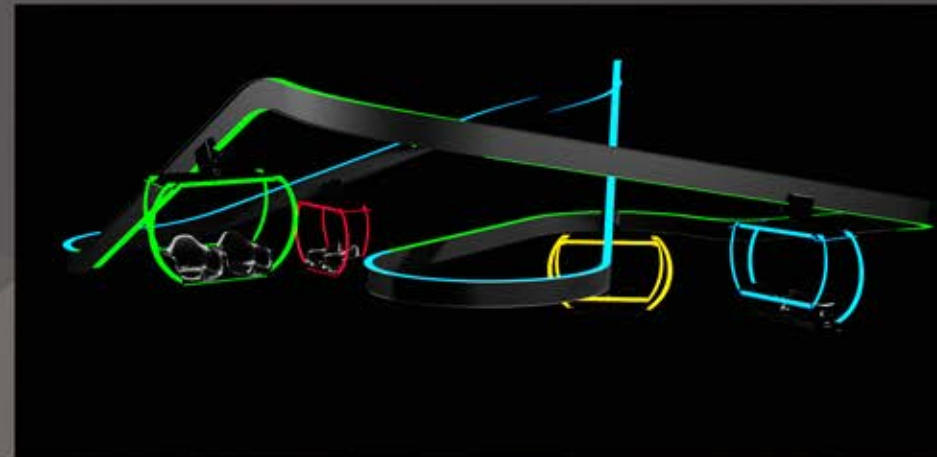
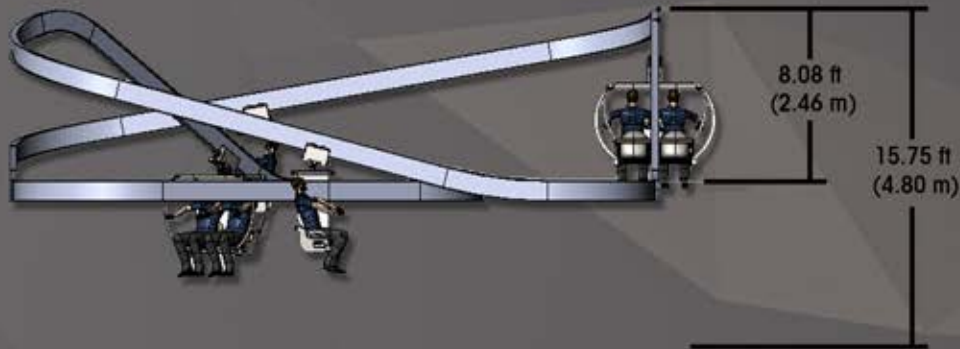
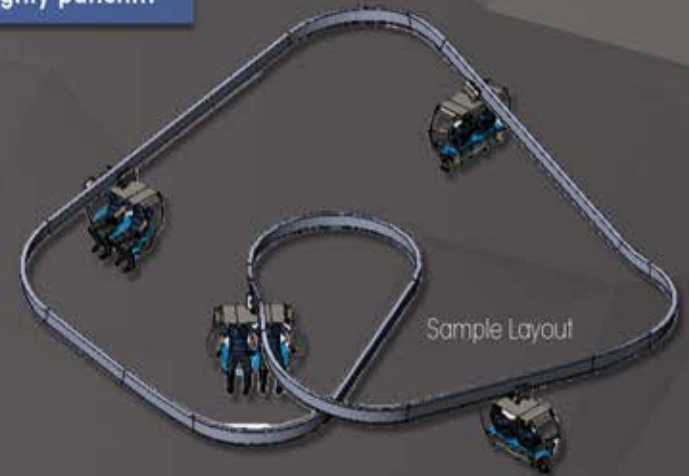
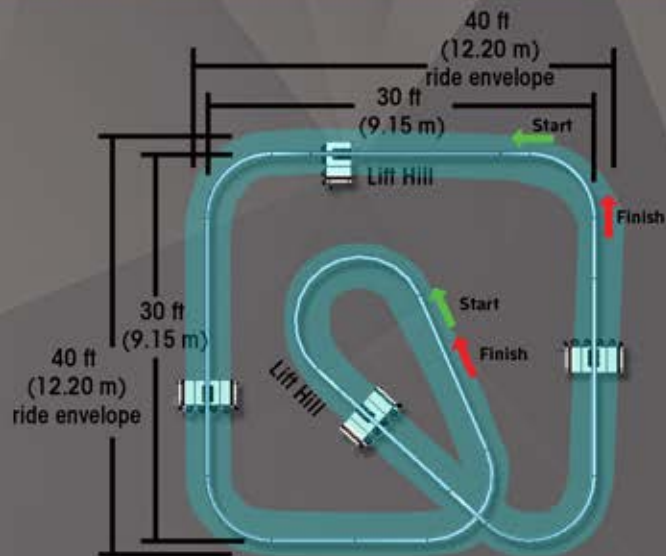

RIDE SPECIFICATIONS

- 171 linear feet of track (52 m).
- 342 linear feet of track travelled (104 m).
- Power requirements: 230V / 40AMPS
- Building height required is 16 ft (4.9 m).
- Vehicle Type: 2-Passenger Side-By-Side.
- Number of Vehicles: 4
- Max Speed: 4 feet per second (1.2 m per second).
- Minimum Rider Height: 40" (100 cm).
- Ride Time: 120 seconds.
- Two Lift Hills (gravity driven).
- Mobius Loop Design.
- Single and Dual Dispatch Stations available.
- Two times around track.
- THRC: 180 - 240 PPH
- Theming Options: Custom colors, ride vehicles, onboard lighting and sounds available.
- Minimum Operators Required: 1

THE SKY TAG™ RIDE VEHICLE

The anatomy of the roller coaster cart

SWIVEL WITH SWAY CONTROL

The precision machined swivel safely attaches the coaster trolley to the Sky Tag's cart. The swivel also provides a dampening feature, for rider comfort, creating the real sensation of flying and floating through the air.

* STEEL CART

The ASTM rated steel cart is used to mount the coaster's seats and restraint system. This steel cart has precision aerospace aesthetics, creating overall weight reduction. Multiple colors options available.

RLR LAP BELT

Two point restraint using a buckle and End Plates.



M.B.S.™ TECHNOLOGY

The M.B.S.™, on the Sky Tag trolley, is an integral part of our passive magnetic braking device. This patent pending design uses magnetic braking, requiring no power, with a lifespan of 300 years! Our rare earth magnets are one-of-a-kind, and the first in the industry, to use Eddy Current principals applied to a coaster cart's trolley. The

M.B.S.™ is also ecofriendly, saving on expensive power requirements needed for other type of braking methods. The M.B.S.™ can be adjusted to apply strong or as little braking force as necessary.

* LASER TAG SENSORS

Each ride vehicle comes with several sensors mounted around the steel cart, giving opponents several locations to shoot their phasers at.

PHASERS

Each ride vehicle comes with two phasers, allowing guests to team up against other riders. These Phasers are packed with exciting features with a full color touch screen, selfie-camera, vibration, voice speaker, and multi-color RGB LEDs.

ERGONOMIC SEAT DESIGN

The coaster seats are custom sculpted, to fit most body types, providing the maximum comfort during use. Seats also have integrated handbars, allowing riders to comfortably hold onto the sides. The coaster seats are extremely easy to sanitize and wipe down.

*Note: Steel cart design and laser tag sensors might slightly differ from image above.

SMALL FOOTPRINT SUSPENDED LASER TAG COASTER

Budget-friendly suspended dark ride that packs a mighty punch...

Sample Layout

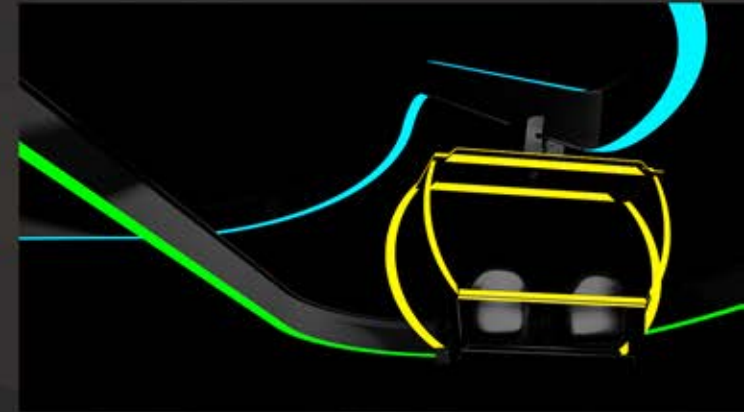
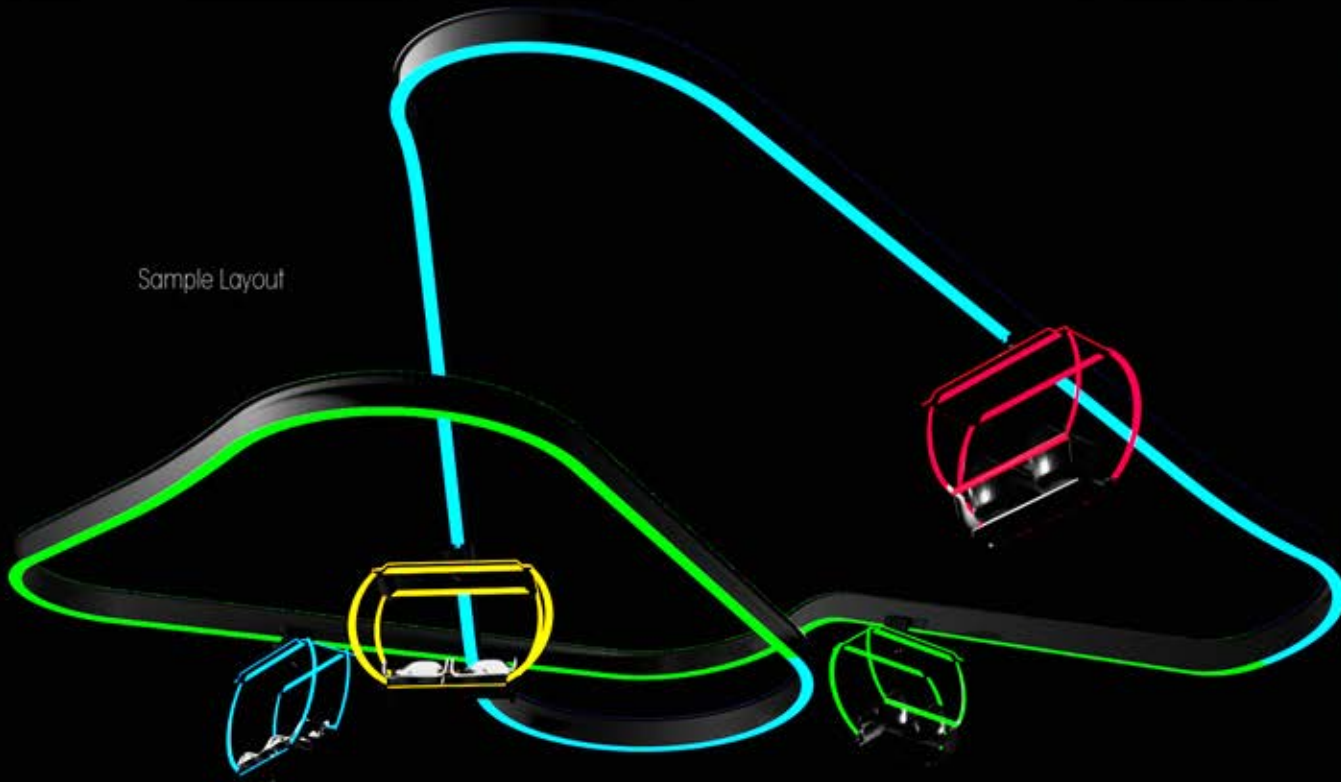

SMALL FOOTPRINT SUSPENDED LASER TAG COASTER

Budget-friendly suspended dark ride that packs a mighty punch...

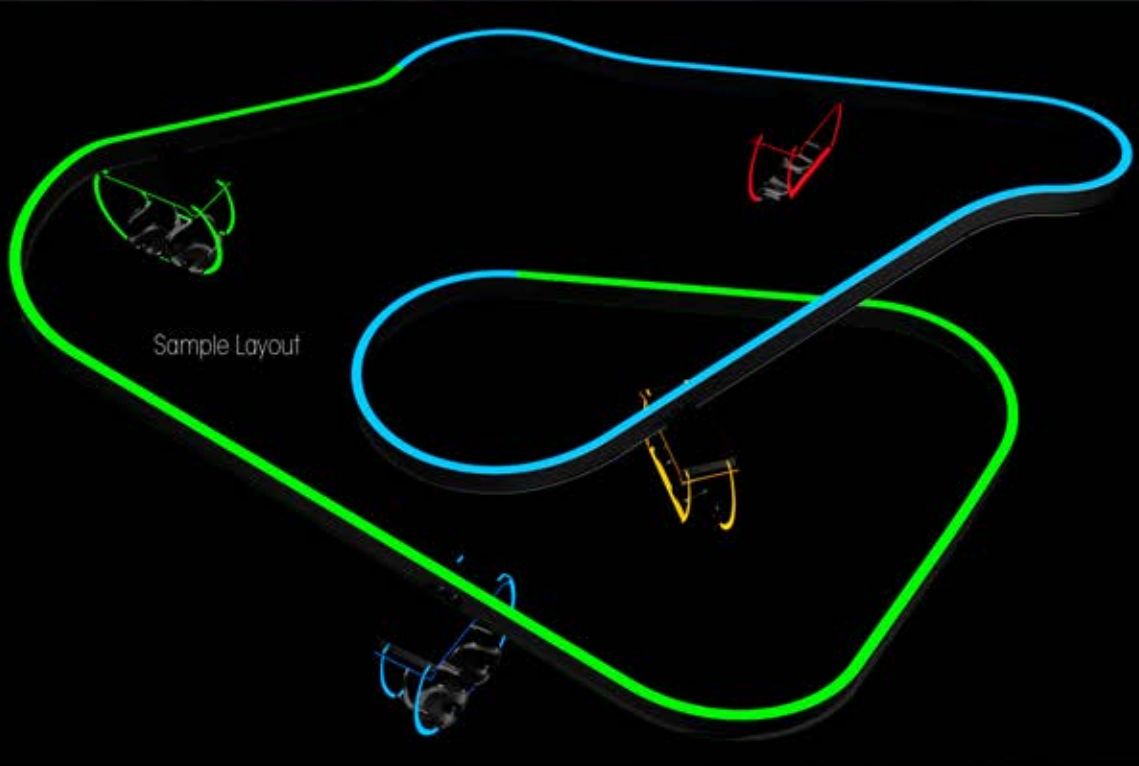

With the Sky Tag, theming is limitless. Battle through space, jungles, old temples and more. Choose your theming to create a fully immersive experience, battling through the sky. Theming and Phaser package included, making this an all-inclusive attraction! Choose from one of the following theming packages below:



CLOUD COASTER STORM



No more riding solo! Family fun is meant to be shared with the all-new Cloud Coaster Storm. This coaster is twice as fast, twice the fun and provides twice the capacity.

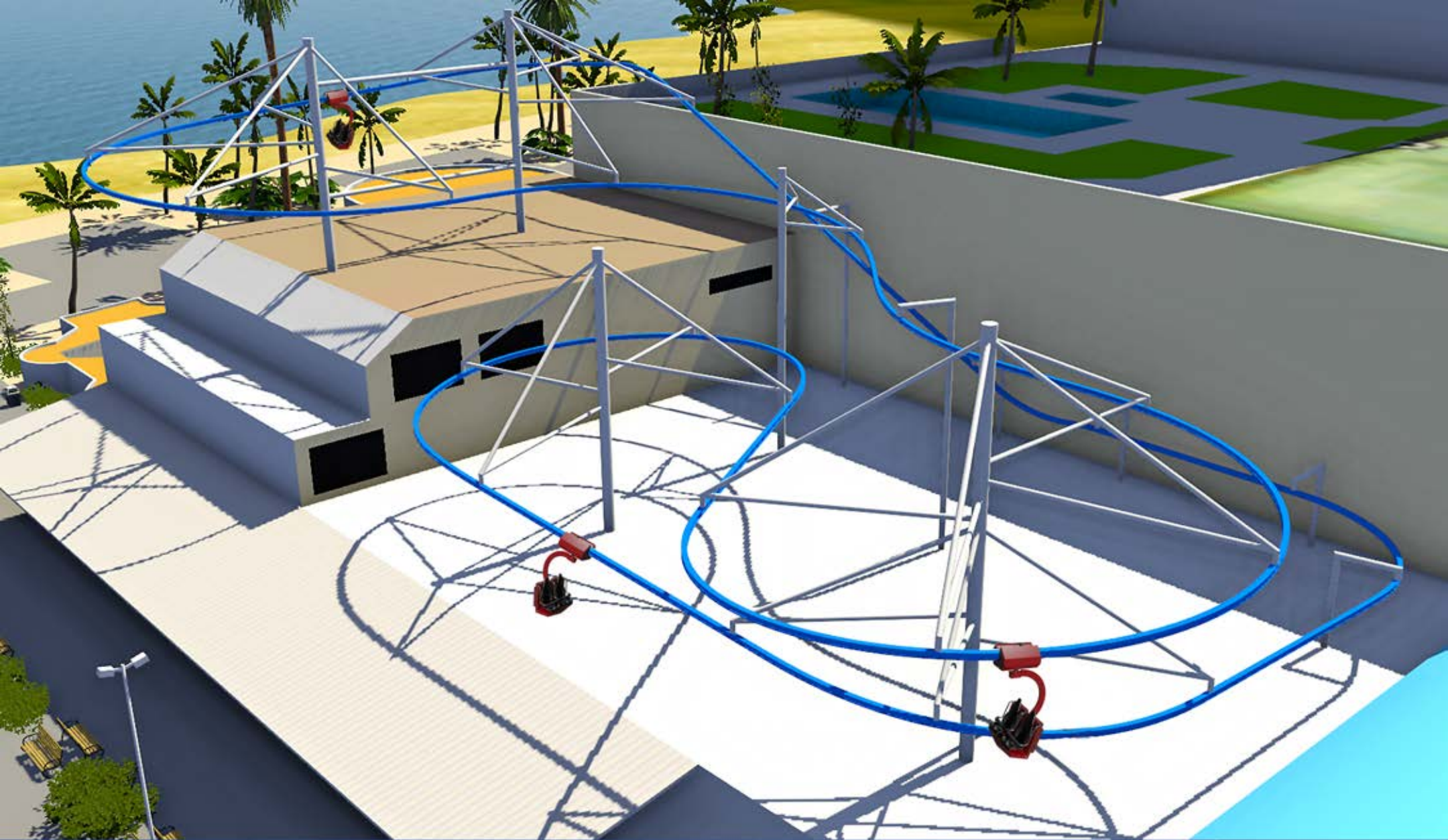

CLOUD COASTER STORM

Experience family friendly thrills together on the all-new side by side suspended roller coaster! No more riding solo as you pair up with your best companion. The Cloud Coaster Storm is a fully scalable, configurable and customizable coaster designed to meet the needs of parks large and small. Feel fully immersed in a life-like storm experience, where you sway side to side on every turn, drop and stops on the all new roller coaster track. Take every corner at fast speeds, feeling the wind against your face while seeing obstacles below. Cloud Coaster Storm is the future in family friendly thrills.

RIDE BENEFITS

Side-by-side fun

Theming Options:

Custom ride vehicles and color options available.

Type of Vehicle:

Two Passenger.

Track Type:

Single or Dual Rail System.

Speed:

Up to 20 MPH (32 Kilometers per hour).

THRC:

Up to 500 PPH.

Minimum Rider Height:

40 inches (100 cm)

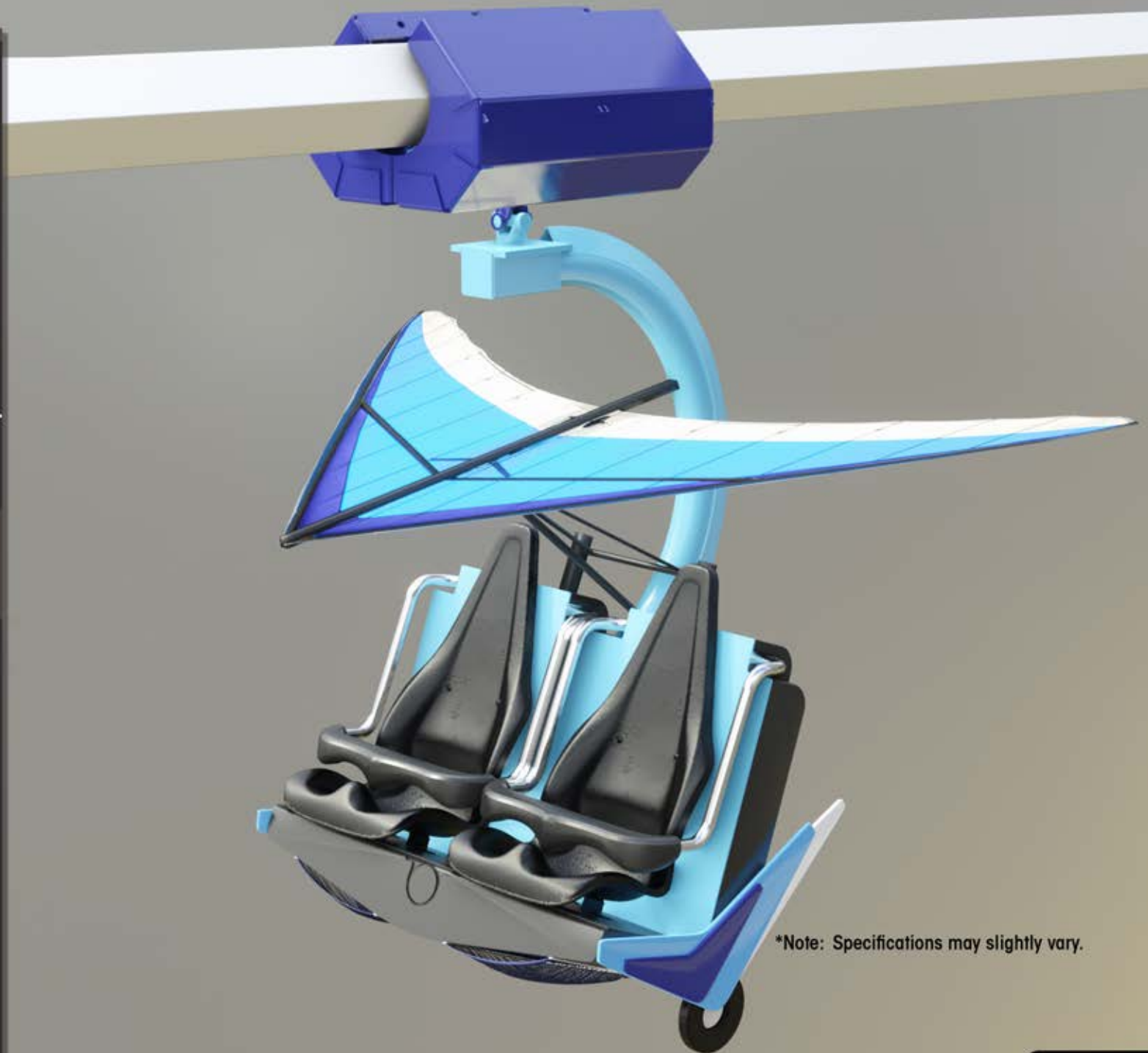

*Note: Specifications may slightly vary.

THE CLOUD STORM CART

The anatomy of the roller coaster cart

M.B.S.™ TECHNOLOGY

The M.B.S.™, on the trolley, is an integral part of our passive magnetic braking device. This patent pending design uses magnetic braking, requiring no power, with a lifespan of 300 years! Our rare earth magnets are one-of-a-kind, and the first in the industry, to use Eddy Current principals applied to a coaster cart's trolley.

STEEL CART BAR

The ASTM rated steel bar is used to mount the coaster's seat and restraint system. This steel cart bar provides aerospace aesthetics and weight reduction. Multiple colors options available.

ERGONOMIC SEAT DESIGN

The coaster seat is custom sculpted, to fit most body types, providing the maximum comfort during use. Seat is made from high-density, closed cell foam, with an extruded fiberglass backing. The coaster seat is extremely easy to sanitize and wipe down. Multiple color options are available.

LOCKING LAP BAR

The locking lap bar provides Infinite adjustments for rider comfort. The electronic release applies hydropneumatics in the riding position. The hydraulic locking unit (HLU) is specifically designed for passenger restraint systems. The HLU is lab tested, easy to use and has proven reliability with high-cycle counts. This device exceeds all international safety standards.

PRECISION WHEELS

Extreme Legacy's machined coaster wheels utilize a proprietary technology, making each wheelset extremely fast, durable and ridged to last plenty of cycles. This technology is designed to freely move carts at rated loads with complete ease. Our wheels also use a urethane polymer designed to provide an extremely smooth coaster experience.

COASTER TRACK

The Cloud Coaster Storm track can use either a single or dual rail system. These tracks are designed to support faster speeds and sharper bends on coaster layouts.

SWIVEL WITH SWAY CONTROL

The precision machined swivel safely attaches the coaster trolley to the cart. The swivel also provides a dampening feature, for rider comfort, creating the real sensation of flying and floating through the air.

ELECTRONIC SAFETY RELEASE

The electronic safety release provides redundancy in the overall safety lock of the lap bar. It is powered by lithium, rechargeable batteries with easy connectivity for recharging. This safety release is located on the backside of the chair, preventing ease of access to riders.

OPTIONAL STORAGE BINS



*Ride vehicle may slightly vary from illustration.

SAMPLE THEMING

Change your experience on the fly

Ski Patrol



Tribal Instinct



Rain Forest





Surfin Tsunami



The award winning Surfin Tsunami is the only stand up surfboard roller coaster on the market. Riders instantly transform into surfers, gliding on a suspended roller coaster surfboard with sharp turns, sudden drops and stops.



Surfin Tsunami

The Surfin Tsunami is the only stand up surfboard roller coaster on the market. This radical roller coaster experience, utilizes all of the great safety and design features found in our three-time award winning Cloud Coaster™. Riders instantly transform into surfers, gliding on a suspended roller coaster surf board while carving into sharp turns and sudden drops. The surfboard ride vehicle allows participants to stand up safely, while easily adjusting to surfers of all ages. Surfin Tsunami provides endless possibilities, offering any desired length, custom theme or track layout. Kick the tide charts to the curb and let the Surfin Tsunami give your guests a surfboard roller coaster experience today!

SURFBOARD RIDE VEHICLE

Wicked brah!



Ride Vehicle Concept Rendering



EST. RIDE ENVELOPE

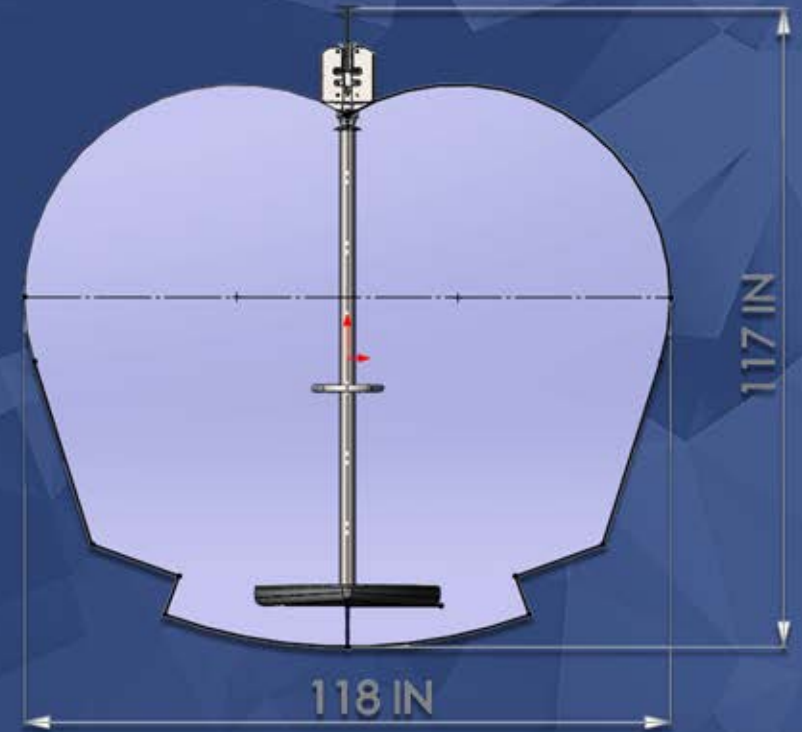

SURFBOARD RIDE VEHICLE

The anatomy of the roller coaster cart

M.B.S.™ TECHNOLOGY

The M.B.S.™, on the Surfin Tsunami's™ trolley, is an integral part of our passive magnetic braking device. This patent pending design uses magnetic braking, requiring no power, with a lifespan of 300 years! Our rare earth magnets are one-of-a-kind, and the first in the industry, to use Eddy Current principals applied to a coaster cart's trolley. The M.B.S.™ is also ecofriendly, saving on expensive power requirements needed for other type of braking methods. The M.B.S.™ can be adjusted to apply strong or as little braking force as necessary.

STEEL CART BAR

The ASTM rated steel bar is used to mount the coaster's seat and restraint system. This steel cart bar has precision drilled holes providing aerospace aesthetics and weight reduction. Multiple colors options available.

HANDLEBARS

The cart's handlebar allows the rider to comfortably hold onto the surfboard style ride vehicle. The handlebar provides the sensation of security, especially for those who can't keep their balance on a board with their feet alone. The Surfin Tsunami's™ handlebar is also designed to provide operators an easy way to control the carts during the end and start of the attraction.

LOCKING LAP BAR

The locking lap bar provides Infinite adjustments for rider comfort. The electronic release applies hydropneumatics in the riding position. The hydraulic locking unit (HLU) is specifically designed for passenger restraint systems. The HLU is lab tested, easy to use and has proven reliability with high-cycle counts. This device exceeds all international safety standards.



PRECISION WHEELS

Extreme Legacy's machined coaster wheels utilize a proprietary technology, making each wheelset extremely fast, durable and ridged to last plenty of cycles. This technology is designed to freely move carts at rated loads with complete ease. Our wheels also use a urethane polymer designed to provide an extremely smooth coaster experience. No aftermarket wheels come close to these precision beauties!

SWIVEL WITH SWAY CONTROL

The precision machined swivel safely attaches the coaster trolley to the Surfin Tsunami's™ cart. The swivel also provides a dampening feature, for rider comfort, creating the real sensation of flying and floating through the air.

ELECTRONIC SAFETY RELEASE

The electronic safety release provides redundancy in the overall safety lock of the lap bar. It is powered by lithium, rechargeable batteries with easy connectivity for recharging. This safety release is located on the backside of the chair, preventing ease of access to riders.

ERGONOMIC SEAT DESIGN

The coaster seat is custom sculpted, to fit most body types, providing the maximum comfort during use. Seat is made from high-density, closed cell foam, with an extruded fiberglass backing. The coaster seat is extremely easy to sanitize and wipe down. Multiple color options are available.

*Ride Vehicle may slightly vary from design,



Optional ADA ride vehicle available.



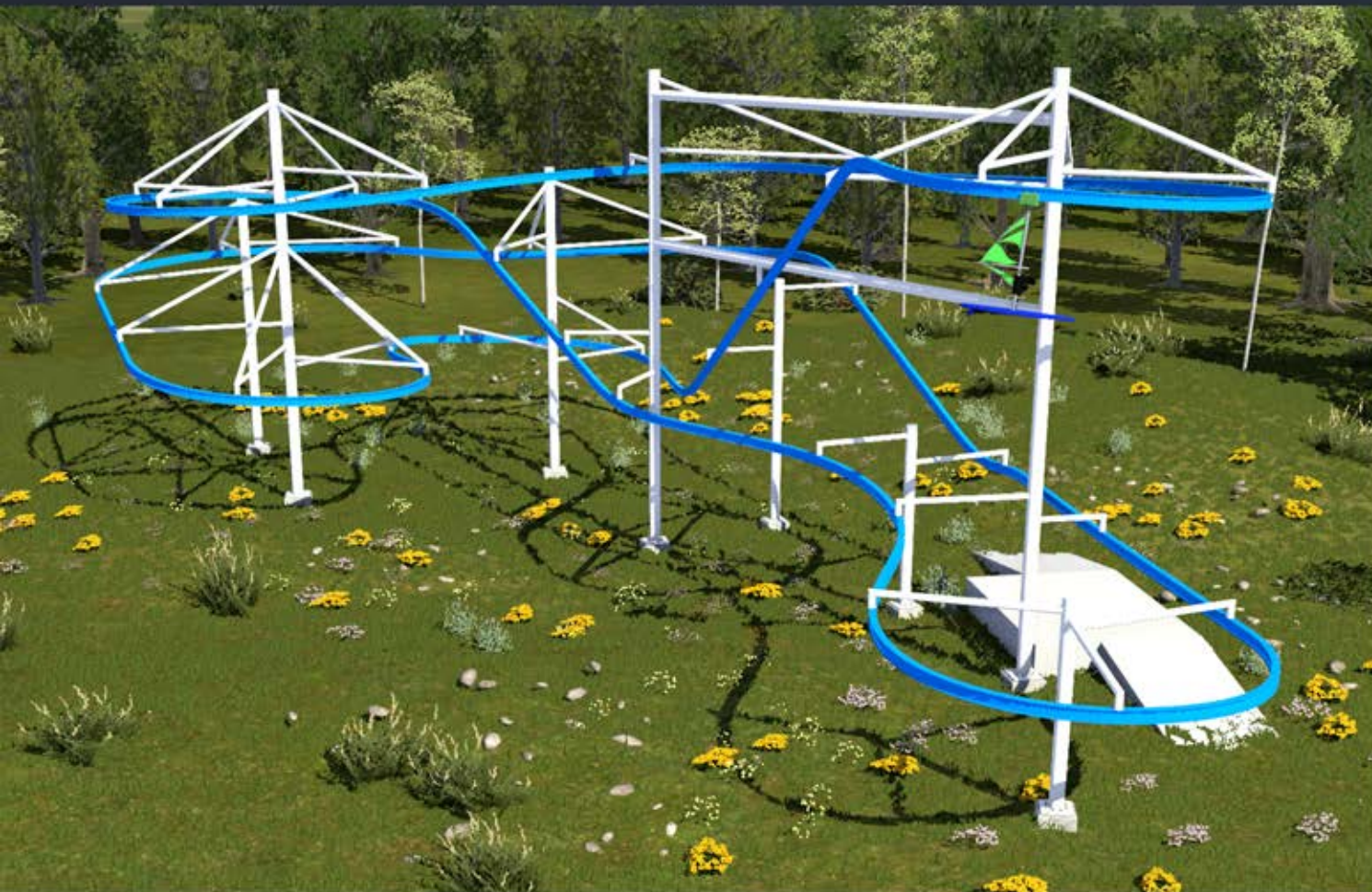



HIGH ACTION ADVENTURE

Our exclusive adventure solution, the High-Action Adventure™, incorporates all of Extreme Legacy's award winning attractions into one place. Guests are transformed into thrill-seekers through rocking down a roller coaster, zip lining, air jumping, conquering challenge courses, rock climbing and more! The High-Action Adventure™ can be scaled, indoors or outdoors, portable or stationary and custom themed to fit into any environment. These attractions are engineered to exceed industry standards, provide safety with no risk, require minimal staffing and are fun for all ages. We invent forward and ensure that your guests experience, live and breathe adventure.

— WE ARE —
**YOUR ADVENTURE
ENTHUSIASTS**

OUTDOOR ADVENTURE

Transform your space into an adventure park

The High-Action Adventure™ can include over five award-winning, anchor attractions! Get a turnkey adventure park starting at \$200,000 USD and up. Talk about a ton of fun and value!

EXTREME AIR™

Soar above others.

Want to know what it feels like to fly? Welcome aboard the Extreme Air™ with nonstop service up to 25 feet in the sky. Stretch out your arms and legs, smell the air, touch the sky and see for yourself why the amazing honor of "Best New Product," two years running, was bestowed upon this powerhouse in the jumping industry. Our patented fiberglass pole technology and wireless control make this product easy to operate.

FLY WIRE™ ZIPLINE

Winner of Best Major Theme Park Ride.

Feel the rush of freedom while you soar at new heights! Thrill-seekers of all ages will lining up to experience an up to 21mph rush on the industry's safest zip line available. The Fly Wire™ is an infinitely adjustable system and uses the safest stopping device on the market, the Decelinator™, which keeps riders safely off the ground at all times.

CLIMBING WALL

Are you ready to rock?

Get ready to turn the volume up to eleven with Extreme Legacy's large assortment of rock climbing walls. Our company was built on the foundation of climbing attractions, specifically designed to provide our customers with a profitable, safe and thrilling experience. We offer various types of climbing attractions to rock your world, if you can handle it.

INDOOR ADVENTURE

Transform your space into an adventure park



The High-Action Adventure™ can be designed for indoor applications, providing a complete, immersive adventure experience for all ages. Incorporate the award winning family coaster, the Cloud Coaster™, and other exclusive Extreme Legacy attractions such as our Extreme Walls, themed climbing structures.



HIGH-ACTION ADVENTURES™

THE ANATOMY OF ADRENALINE

Leave the 9-5 behind...you're on an adventure.

The High-Action Adventure™ can generate serious revenue as an additional attraction or added value piece.

The High-Action Adventure™ provides your business more on-site activities for your guests to enjoy. This is the perfect attraction to enhance the stay-to-play experience.

Guests do not have to leave your property for entertainment! Each interactive attraction provides guests a unique, hands-on experience. The DNA in each ride screams fun!

This solution is designed to attract families of all ages.

The High-Action Adventure™ incorporates popular attractions all in one place.

All of our award winning attractions are engineered to offer the very best in quality and safety. Every product we manufacture meets and/or exceeds industry standards. If you want innovation at its best, then look no further.



IT'S FUN FOR ALL AGES!

WHERE WILL YOUR ADVENTURE TAKE YOU?



You get them to check-in,
we get them to check you out...



Designed to attract families and guests, of all ages, the High-Action Adventure™ can generate serious revenue as an additional attraction or added value piece to your already stellar rides.

From start to finish, we help you design a unique, fun experience to provide your guests. Our stay-to-play concepts allow your creativity to shine.

Our award winning design team carefully focuses on interactive attractions that are popular in today's market. We ensure that all of our adventure rides are created for the next generation of thrill-seekers.

The High-Action Adventure™ is scalable, can be themed and is designed to be both outdoors and indoors.



Our process is simple. Here is how it works:

1. You provide us with your available space.
2. We present you with layouts, options and illustrations.
3. We assist you in the correct product mix.
4. You give us your theming desires, we create the reality.
5. We install your equipment, train your staff and help with any promotions necessary.
6. Your guests start having fun, you start making money.

THEMING AND DESIGN



Fly like Tarzan, be a swashbuckling pirate or go on a safari adventure...

Let's Co-Create! You provide the vision, we provide the experience. Our in-house theming experts provide world-class solutions to fit into any environment. From rendering to reality, allow your creativity to shine while creating the adventure of your dreams. From start to finish, we help you design a unique, fun experience to provide your guests an adventure to remember.

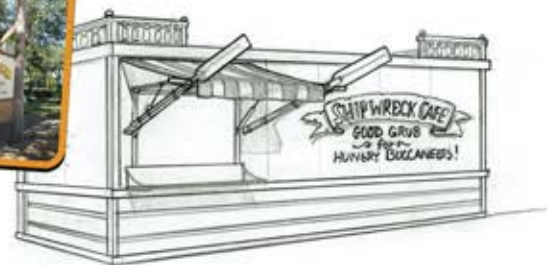



ATTRACTION DATA

The award winning High-Action Adventure™ parks, winner of Best Resort Amenity by ARDA (American Resort Development Association) can be scaled to fit within any indoor or outdoor environment, including an endless mix of exciting adventure rides.



PRICE

These projects can range between \$200K USD and up. Each park is designed to meet your clients' budget, capacity needs and experience.

LEAD TIMES

Depending the complexity of your adventure park, we can turnkey a project in as quickly as 3 months. Typically most projects take 4-6 months from design, engineering, production to installation. We are proud to say our adventure parks install quickly so you can start making money sooner.

OPERATIONAL SPACE

The operating space of our adventure park layouts can be designed to minimize the impact at your park. We can fit over 6 attractions easily within 20,000 SQ FT!



LOCATIONS

We have projects, with projects pending, in the following locations:

- Kissimmee, Florida, USA
- Orlando, Florida, USA
- Canada
- Aruba
- River Ranch, Florida, USA
- Phoenix, Arizona, USA
- Spokane, Washington, USA
- Malaysia
- China
- Ghana
- El Paso, Texas, USA



GET READY TO TAKE FLIGHT



FLY WIRE **A ZIPLINE RIDE**

The Fly Wire™ zipline has gained traction and notoriety as the only “Best Major Theme Park Ride” zipline – one of the highest industry honors – for its brilliant design and savvy configuration. A spiral staircase leads to a zipline tower, which allows two riders at the same time on two lines. This zipline configuration is the safest and fastest in the world, requiring no additional anchoring or attachments. The Fly Wire™ zipline attracts thrill seekers of all ages and is perfect for enhancing your family-friendly entertainment offerings.

The Fly Wire™ zipline uses the safest, proprietary decelerator on the market, The Decelinator™. Awarded best technology applied by the amusement industry, this product has been used by resorts, theme parks and entertainment centers worldwide. Specifically designed to slow down the zip liner without sacrificing the length of the zipline, riders slow down at the very end of the ride, providing maximum thrills.

Ease of set up, half the operators, standard lengths of 500 feet or longer lengths available, the Fly Wire™ zipline is the safest, most thrilling choice on the market for adventure enthusiasts.

TOTALLY EXHILARATING.

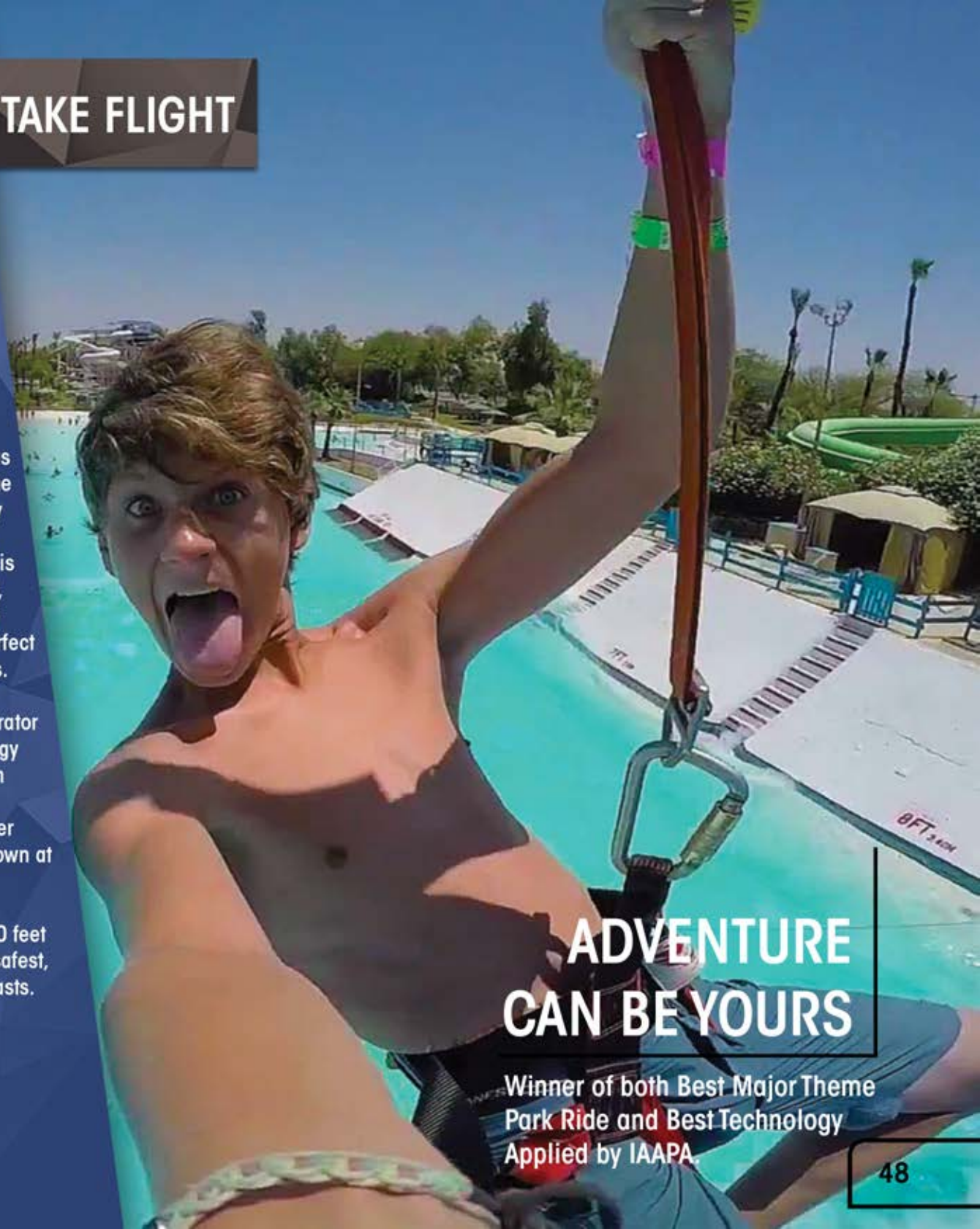

**ADVENTURE
CAN BE YOURS**

Winner of both Best Major Theme
Park Ride and Best Technology
Applied by IAAPA.



Yes, you can zipline over waterparks, resorts, clear football fields and fly over amusement parks with our Fly Wire™ zipline, the only awarded Best Major Theme Park zipline on the market.

Custom Length Available Upon Request



OUR FEATURES ARE FOCUSED ON YOU

We work closely with leaders in our industry to provide solutions that really work. The Fly Wire™ zipline is the future in family-friendly entertainment. Here's the dish:



DECELINATOR™

The Decelinator™, awarded on technology, is a proprietary device that fully lowers zip-liners safely to the ground. The hydraulically activated Decelinator™ raises up in the air, keeping zip liners safely off the landing area. Once the zipline trolley descends into a "Power Pack," a variable rate shock, the zip-liners are safely slowed down at the end of each ride. When the zip liners are stopped, they are hydraulically lowered safely to the landing area.

SPIRAL STAIRCASE

A spiral staircase leads to a zipline tower, which allows two riders at the same time on two lines. This zipline configuration is the safest and fastest in the world, requiring no additional anchoring or attachments.

MOBILE VERSION AVAILABLE

Industry's most popular and longest mobile zipline on the market. Set up in just 45 minutes and zipline up to a football field length (300 feet / 91 meters)!





ATTRACTION DATA

The Fly Wire™ zipline has gained traction and notoriety as the only “Best Major Theme Park Ride” zipline – one of the highest industry honors – for its brilliant design and savvy configuration. A spiral staircase leads to a zipline tower, which allows two riders at the same time on two lines. This zipline configuration is the safest and fastest in the world, requiring no additional anchoring or attachments with the safest, proprietary decelerator on the market, The Decelinator™. Awarded best technology applied by the amusement industry. Ease of set up, half the operators, standard lengths of 500 feet or longer lengths available, the Fly Wire™ zipline is the safest, most thrilling choice on the market for adventure enthusiasts.

LEAD TIMES

Normal Lead times for the Fly Wire™ zipline attraction are just 6-8 weeks.

OPERATIONAL SPACE

The space required for operations are: 31’ tall X 8’ wide and up to 500’ long for standard zipline lengths. Custom lengths and configurations are also available.

LOCATIONS

We have projects, with projects pending, in the following locations:

- Kissimmee, Florida, USA
- Orlando, Florida, USA
- Canada
- London, England
- Aruba
- River Ranch, Florida, USA
- Phoenix, Arizona, USA
- Gatlinburg, Tennessee, USA
- Malaysia
- China
- California, USA



The Auto-Zip™ utilizes our patented Auto-Belay™ technology, keeping tension on the zipline cable at all times. This zipline attraction is great for all ages. If they fit securing in the harness, they can zipline. It's that simple and is simply just fun!





ATTRACTION DATA

Provide zipline thrills at your indoor facility with the Auto-Zip,TM the perfect indoor zipline solution.



LEAD TIMES

Lead times for the Auto-ZipTM attraction is very quick. Turnaround times are just 3-4 weeks.

OPERATIONAL SPACE

The space required for operations are: 18' tall X 8' wide and 60' long. Each Auto-ZipTM allows one zip-liner at a time.

LOCATIONS

We have projects, with projects pending, in the following locations:

- Texas, USA
- Florida, USA
- Washington, USA
- New York, USA

NONSTOP SERVICE TO THE SKY



EXTREME AIR

Welcome aboard the Extreme Air™, with nonstop service up to 25 feet in the sky. Stretch out your arms and legs, smell the air, touch the sky and see for yourself why the amazing honor of "Best New Product" two years running was bestowed upon this powerhouse in the jumping industry. Every patented jumper system comes with the best features on the market and meets ASTM and other industry standards.

Extreme Legacy only uses the best materials available in the production process of every Extreme Air™ jumper. The extruded fiber-woven poles, "Flex Pole Technology™," supports a wide range of weights. With faster cycle times, wireless remote technology, less staff and less maintenance costs, you will be jumping for joy with the Extreme Air™.

SOAR ABOVE OTHERS.



ADVENTURE CAN BE YOURS

Awarded best new product, two years in a row, by IAAPA. This is the best jumper on the market.

OUR FEATURES ARE FOCUSED ON YOU

We work closely with leaders in our industry to provide solutions that really work. This is why the Extreme Air™ is the only two-time jumperr winner at IAAPA.



FLEX POLE TECHNOLOGY™

The patented "Flex Pole Technology,™" allows operation of the equipment without cumbersome turn buckles and bungee cords. This exclusive pole technology, with an inflatable pad, allows participants to spring up to 25 feet in the air with ease. The poles store crazy amounts of energy and are incredibly strong (can hold over 5,000lbs).



UP TO 4 RIDERS AT A TIME

The Extreme Air™ will take you leaps and bounds above the competition! Allow up to 4 riders at a time. You'll be able to move participants quickly on and off the product, enhancing profitability. The operator has complete custom remote con-

MOBILE VERSION AVAILABLE

Industry's most popular mobile jumper on the market. Set up in just 20 minutes and allow up to 4 riders at a time!



The Extreme Air™ jumper exceeds ASTM and other industry standards.



TANDEM JUMPER CONFIGURATION

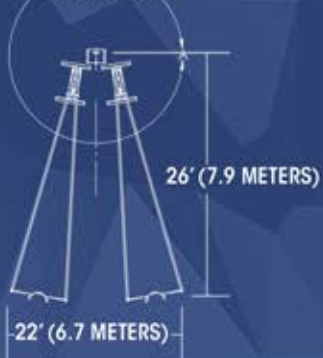

QUAD JUMPER CONFIGURATION

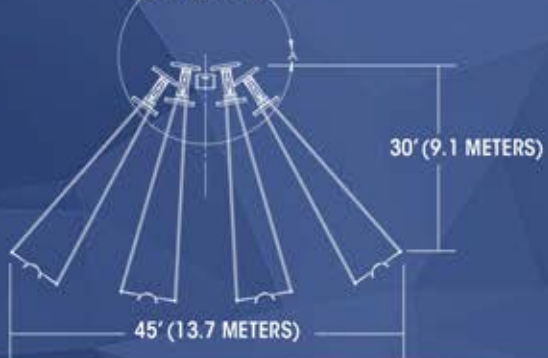

INFLATABLE PAD SIZE

12' (3.6 METERS)

8' (2.4 METERS)

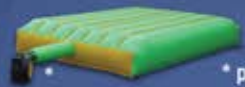

* pad color may vary.



Single Extreme Air™ units also available.



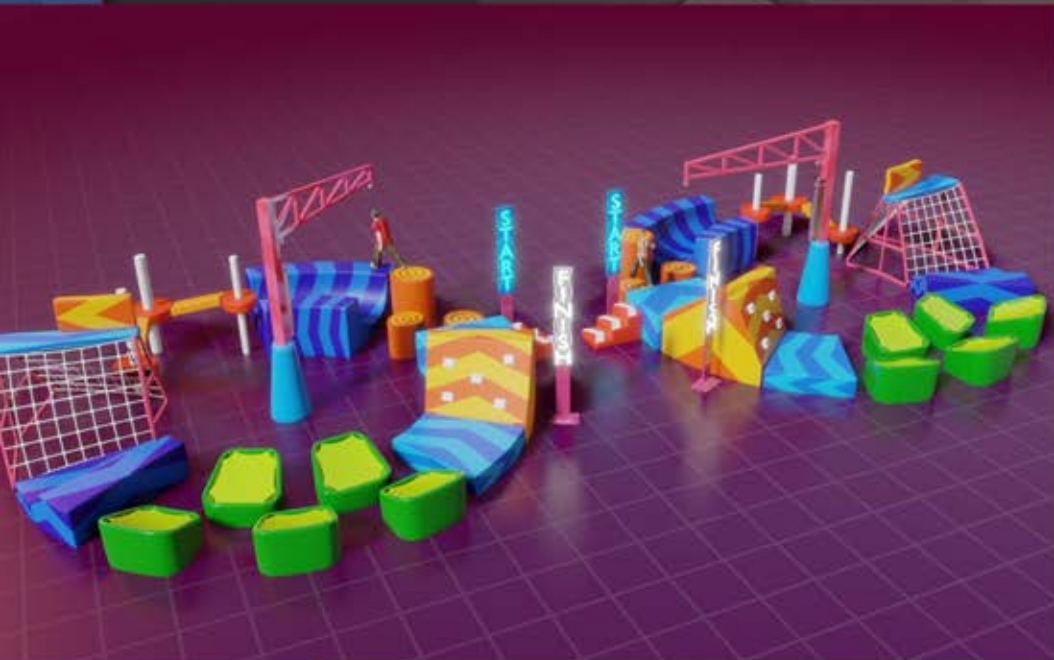

Parkour™ Around

Freerunning Fun

Winner of the prestigious IAAPA Brass Ring Award for "Best New Product Concept," the Parkour Around takes free-running fun to the next level. Dive into a parkour experience like never before!

The Parkour Around features our patent-pending Power Assist system, which helps participants navigate each element with ease. This design is inclusive for all ages and abilities, enabling everyone to test their strength and bravery through one of today's most popular activities.

The safety restraint system alleviates pressure on participants, making it easier to conquer challenging obstacles, such as jumping long distances that would normally be beyond human capability. This attraction transforms you into a superhero, allowing you to leap incredible distances, run up ramps, and soar over towering pillars. It's like stepping into the heart of your favorite adventure video game!

The circular layout makes the Parkour Around attraction highly modular, reducing operational space by 30%. It can also connect to an online network, enabling participants worldwide to compete for the fastest time.

The Parkour Around Experience

Race participants, while restrained to the patent pending Power Assist system, on the most ultimate parkour experience. Achieve obstacles that are not normally humanly possible with the assist system. The assist system safely secures riders, as well as taking pressure off the ground, allowing participants to launch to great lengths, soar up high structures, to even run sideways on ramps. The Parkour Around turns the ordinary into extraordinary. You go from zero to superhero in just seconds! Jump, run, climb and soar your way to the finish line. This concept is designed to help make the parkour experience accessible to all ages and abilities.





The Parkour Around Jr. Experience

Just like our award winning Parkour Around, the Parkour Around Jr. provides the same exciting experience catered towards toddlers and small children. The assist system safely secures small riders, as well as taking pressure off the ground, allowing them to launch to great lengths, soar up high structures, to even run sideways on ramps. The Parkour Around Jr. is smaller in operational size, allowing the attraction to fit in small areas and low ceiling heights.



ARE YOU READY TO ROCK?

ROCK CLIMBING WALLS

Get ready to crank up the excitement with Extreme Legacy's wide selection of rock climbing walls! We now own the company that laid the groundwork in designing rock climbing walls, built to provide users with an exhilarating, safe, and profitable experience.

Since 1995, Extreme Engineering has pioneered the first-ever mobile climbing wall and Auto-Belay system. Now Extreme Legacy is recognized globally for making climbing accessible and a favorite within the amusement industry. Today we offer an expansive range of climbing surfaces, themed attractions, and continue to lead in mobile climbing wall solutions.

As the industry leader in climbing attractions, we are committed to delivering the most thrilling and safest experience available. Each Extreme Legacy climbing wall can be outfitted with our patented Auto-Belay system, the safest belay device on the market. All of our climbing attractions provide the highest quality features on the market and adhere to ASTM and other industry standards.

**ROCKING THE WORLD
SINCE 1995**

**ADVENTURE
CAN BE YOURS**

We are the ultimate choice in transforming your guests into thrill seekers!



The GeoWall is both a climbing wall and traversing structure that uses geometric shapes with a futuristic twist. This climbing attraction provides architectural style and functionality in one. GeoWall's traversing models are perfect for kids, requiring no safety gear when in operation. Toss the climbing harness and ropes aside, just go for it!



BOULDERING AND TRAVERSING WALLS

We can co-create the perfect GeoWall to fit within a unique floorplan, providing you an aesthetically pleasing climbing structure that won't break the bank. With endless color options, handhold selections and traversing wall lengths the GeoWall can be configured to achieve almost any climbing experience imaginable.

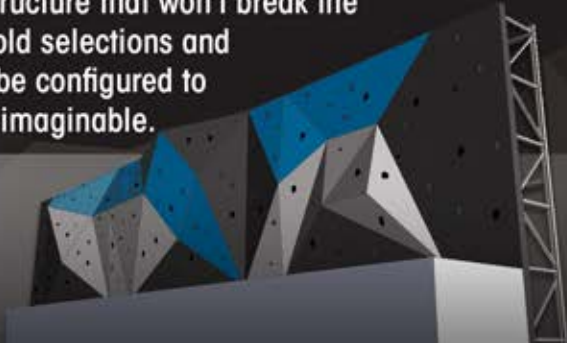

Traversing, scaling, climbing, bouldering or just hanging out.
The GeoWall can do it all!



CUSTOM CLIMBING TOWERS



Choose your challenge, choose your route. Those who want to conquer great heights can do so on the GeoWall climbing structure. Design the most epic climbing attraction, utilizing geometric shapes, with an endless combination of colors and shapes. Each GeoWall can be fully scalable and customized to tailor your unique climbing experience. Whether it's a climbing introduction for beginners or a competitive marvel for professionals, we've got you covered. Let's design you the best climbing attraction with the best visual impact today.



ATTRACTION DATA

This GeoWall is the best climbing attraction that can be scaled, customized and stylized to meet your branding needs.



LEAD TIMES

Depending on the GeoWall project, turnaround times are quick. We can get you climbing in just 4-6 weeks.

OPERATIONAL SPACE

The operational space required for the GeoWall is 4 feet deep and comes in 4 foot sections. Height is typically no more than 12 feet for traversing walls. The height can vary on climbing towers.



LOCATIONS

We have projects, with projects pending, in the following locations:

- Texas, USA
- Florida, USA
- California, USA
- Washington, USA
- New York, USA
- New Jersey, USA
- Illinois, USA
- North Carolina, USA
- Georgia, USA
- Indiana, USA
- Alabama, USA
- Arkansas, USA



**GEO WALL
ARCADE**



DON'T JUST CLIMB, PLAY!



Don't just climb a wall, play on it! Extreme Legacy's GeoWall Arcade provides an exciting way for climbers to scale a climbing wall and play up to 5 digital games, increasing engagement with attractive storylines. Players of all ages can interact with the vibrant, sound activated LED sensors, programmed with various video gaming modes. Interact with a touchscreen, choose your challenge and let the games begin! Bring an interactive arcade experience to great heights.



PUT THE JOYSTICK DOWN AND LOOK UP

Players can compete with friends or just enter single player mode. It's up to the participant to choose their fun experience. Geowall Arcade can be applied to most Extreme Legacy's climbing walls. Best of all, the GeoWall Arcade is a turnkey solution that includes everything to turn a climbing wall into an exciting arcade game experience!



The GeoWall Arcade is compatible with traversing, bouldering or climbing walls.



*Game modes subject to change.

CHOOSE YOUR GAME MODE, THEN PLAY.

With on demand play, participants can choose 5 different game modes. Each game last about a minute long, providing enough time for a great experience and fulfill capacity needs.

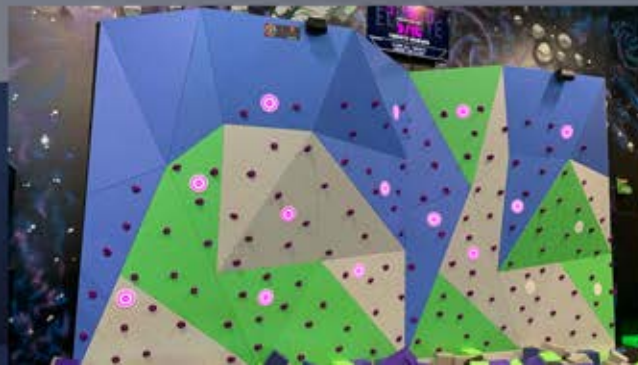



ATTRACTION DATA

The Geowall Arcade comes fully equipped, ready for play. This kit includes the following:

- LED sound and light activated targets.
- Touchscreen play pad.
- Television display.
- Power supply.
- Speakers
- Wiring
- GeoWall climbing wall (prices and sizes vary).

LEAD TIMES

Depending on the GeoWall Arcade project, turnaround times are quick. We can get you climbing in just 4-6 weeks.

Story & Game Examples

- 🕒 **HOT POTATO** Two Player Game - Player 1 hits a sensor to light up a random sensor for Player 2. Player 2 then has to hit the same sensor in under 45 seconds. When Player 2 hits the sensor, Player 1 must hit the sensor in under 30 seconds. Each time the sensor is hit the time reduces until a player loses.
- 🕒 **NUCLEAR MELTDOWN** A nuclear reactor has entered into meltdown. Only you can save the town. You have to release the cooling valves in the correct sequence to cool the reactor.
- 🕒 **ACCESS GRANTED** Working with archeologist in the depths of Mexico, you have to follow the Lead Archeologist's directions to unlock the Mayan Ruins to find the lost chamber of Gold.
- 🕒 **FROST BITE** Winter is coming and you must heat up the wall to keep from getting frostbite. Each activation acts against the frost but speed is necessary to push back. How long can you last?



Our Extreme Walls allow you to choose from a wide range of themed climbing structures, branded elements and even provide a "Parkour" experience. Scale a building, climb up shipping containers and ropes or be immersed in the middle of retro video games and even futuristic worlds!



Your experience is limitless! With lights, glow-in-the-dark elements, black light infused climbing panels, video projections, custom shapes to digital timers, ... our engineers can co-create the perfect climbing attraction at your park's next adventure.

DESIGN YOUR CLIMBABLE WORLD...





ATTRACTION DATA

Extreme Walls come in any theme imaginable. Choose from an unlimited combination of themed climbing attractions. We create your climbable world.

LEAD TIMES

Depending the project, turnaround times are quick. We can get you climbing in just 4-6 weeks.

OPERATIONAL SPACE

The operational space required for the Extreme Wall is 4 feet deep and comes in 4 foot sections. The height is no more than 24 feet tall.

LOCATIONS

We have projects, with projects pending, in the following locations:

- Texas, USA
- Nevada, USA
- North Carolina, USA
- Washington, USA
- New York, USA



Mount Everest. The Andes. Denali... Experience a climb without altitude sickness. Extreme Legacy's "Solid Systems" are cost-effective while using the highest quality materials available to offer a thrilling, life-like climbing experience. Quickly becoming a mainstream product in high-end facilities, stationary rock climbing walls enrich entertainment centers and provide success to entrepreneurs worldwide, and can always be enhanced and reconfigured to create a new adventure.





Molded from real rock and can feature dinosaur fossils, ice from the Arctic and sandstone you would see in the desert, climbers are in awe over these realistic climbing surfaces. Scale the mountain to get a view of the world above the clouds. As a full tower, this solid system allows up to 10 climbers standing at a massive height of 32 feet tall.

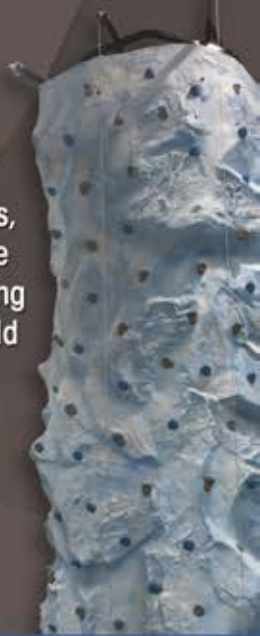

MOBILE CLIMBING WALLS

Adventure on the go! All of our solid systems are available as a portable climbing wall. Extreme Legacy has the most experience in engineering and design of mobile adventure equipment in the world. All of Extreme Legacy's mobile products have won Best New Product awards and are built from the best quality materials available. Every product we design exceeds ASTM, CE and other industry standards. We only provide the best, engineered adventure products available



ATTRACTION DATA



The Solid Systems can be configured into half or full towers, allowing up to 10 climbers at a time. We offer two models, each molded from real rock.

Typical Free-Standing
1/2 Tower

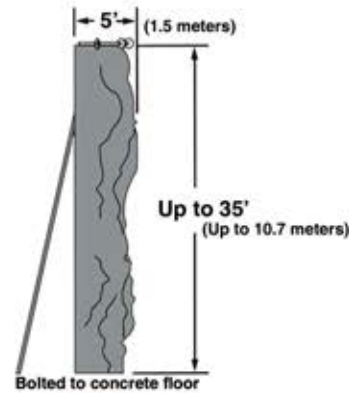
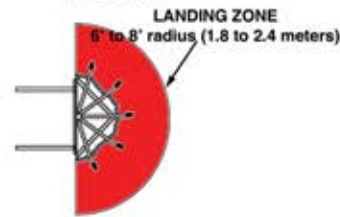

Bolted to concrete floor

Typical Flush Mount
1/2 Tower

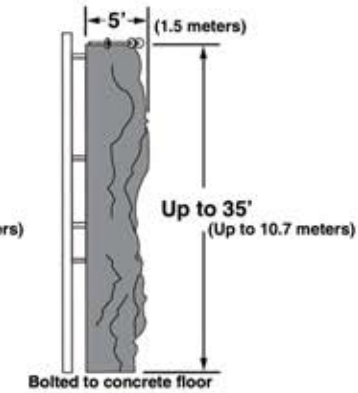
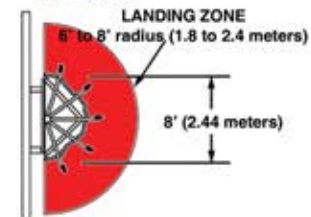

Bolted to concrete floor and architectural wall

Typical Free-Standing
Full Tower

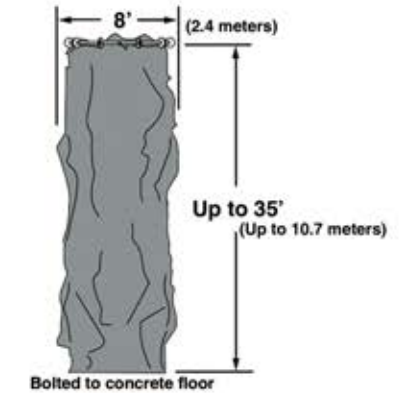
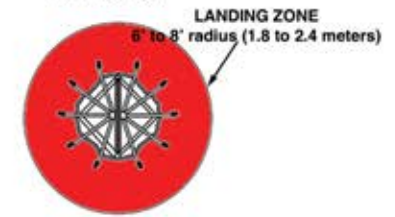

Bolted to concrete floor

LEAD TIMES

Depending on the project, turnaround times are quick. We can get you climbing in just 4-6 weeks.

OPERATIONAL SPACE

The operational space required for the Sierra Panel System is 4 feet deep and comes in 4-foot sections. The height is typically no more than 35 feet tall.

LOCATIONS

We have projects, with projects pending, in the following locations:

- Texas, USA
- Florida, USA
- California, USA
- Washington, USA
- New York, USA
- New Jersey, USA
- Illinois, USA
- U.K.
- Maldives
- Korea
- China
- Italy

BELAY IN THE BOX - AUTO-BELAY



There's safe and then there is Extreme Legacy safe. The patented Auto-Belay, is included on almost every Extreme Legacy climbing wall provided today. Extreme Legacy's Auto-Belay

system simply takes up the slack when a participant starts to climb up the climbing wall. Once the participant is done climbing, the pressure from the device will safely lower the participant slowly to the ground. The Auto-Belay systems can be installed on steel or wood treated substructures. Extreme Legacy's Auto-Belays are perfect for rope courses, climbing gyms, fitness centers and search and rescue. This is the primary solution to any existing climbing structure in need or replacement of a belay device! Awarded Best Technology Applied by IAAPA (International Association of Amusement Parks and Attractions). All Extreme Legacy's Auto-Belays meet ASTM and other industry standards.

ADVENTURE ON THE GO

We are the leaders in mobile adventure.

MOBILE CLIMBING WALLS

Extreme Legacy is a global leader in the design and engineering of mobile adventure rides. Our innovative attractions have consistently won Best New Product awards and are crafted using top-quality materials. Each attraction we develop adheres to ASTM and other industry standards, ensuring that we offer only the best-engineered adventure rides on the market.

Going mobile offers numerous benefits for your business and promotional activities. All of Extreme Legacy's mobile attractions are designed for quick setup and effortless relocation, whether on-site or at various destinations. The flexibility of our mobile adventure rides allows you to adjust and enhance your adventure experiences at any time, keeping things exciting and adaptable.





As Shown Element Mobile 4 Climber Sandstone

Extrême Legacy has more mobile climbing wall experience than all the competition combined.

Bring the most popular, patented mobile climbing wall to your event today. Every patented mobile climbing wall comes with the best features on the market and meets ASTM, and other industry standards.

We provide the engineering geek, marketing sleek and business sales success all in one! Our products are designed by a team of the most talented aeronautical and mechanical engineers, business professionals, and marketing gurus in the world. Extrême Legacy only uses the best materials available in the production process of every mobile climbing wall. These products are stronger than real rock!

**WE ARE
YOUR ADVENTURE
ENTHUSIASTS**



MOBILE CLIMBING WALLS

Our patented mobile climbing walls are perfectly designed as a thrilling and profitable business opportunity! Extreme Legacy's mobile rock climbing walls are used for entertainment, team-building exercises, recruiting tools, exciting promotional billboards and are a signature product for any party rental business. Using only the best materials available, all of our patented mobile climbing walls are built to be extremely strong and lightweight, so you can roll wherever you'd like to go. Our patented mobile climbing walls are safe, fun and a successful marketing and promotional tool. With the popularity in thrill seeking sports, Extreme's mobile climbing walls have become an exciting team-building experience, enhance entertainment driven facilities and provide success to entrepreneurs worldwide. This is a life changing activity.

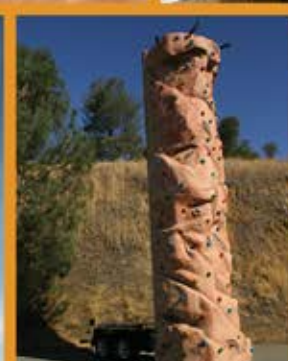
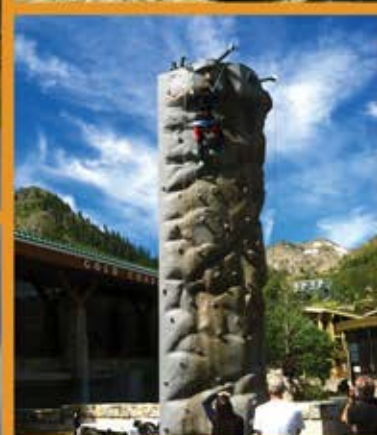
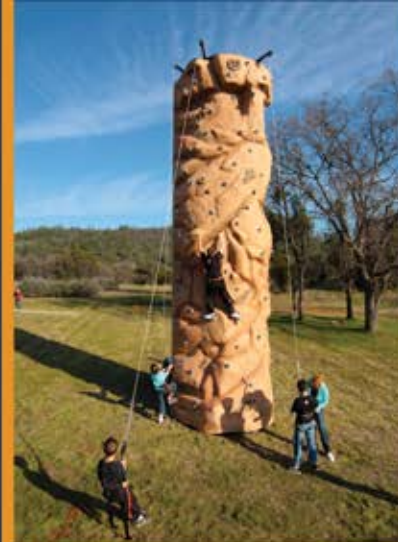

ELEMENT CLIMBING WALL

Mobile Element (3 or 4 Person Climbing Wall)

TAKE A PIECE OF EARTH WITH YOU.

Weight Limit:	45-250 lbs (20-114 KG)
Climbers:	3 or 4 climbers
Height:	26' (7.9 Meters)
Surface Area:	390 SF (36.1 Meters)
Travel Height:	9'0" (2.7 Meters)
Travel Width:	8'0" (2.4 Meters)
Dry Weight:	4,200 lbs (1,909 KG)
Brake:	Electric 12 Volt
Auto-belays™ :	Fully Redundant

Extreme Legacy are the pioneers in revolutionizing the climbing experience. The patented Auto-belay™, is included on every Extreme Legacy mobile climbing wall.

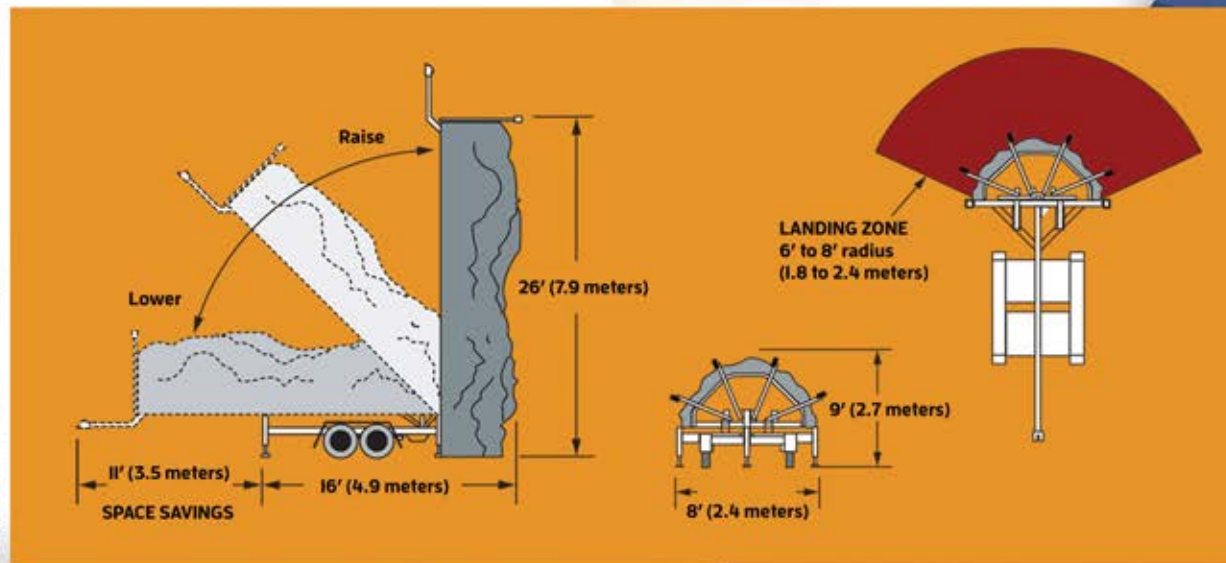

MONOLITH CLIMBING WALL

Mobile Monolith (5 Person Climbing Wall)

THE KING OF MOBILE CLIMBING WALLS.

Weight Limit:	45-250 lbs (20-114 KG)
Climbers:	5 climbers
Height:	26' (7.9 Meters)
Surface Area:	524 SF (47.6 Meters)
Travel Height:	10'0" (2.7 Meters)
Travel Width:	8'0" (3 Meters)
Dry Weight:	4,600 lbs (2,090 KG)
Brake:	Electric 12 Volt
Auto-belays™ :	Fully Redundant

The Monolith has over 500 square feet of climbing area, multiple overhangs, five distinct climbing routes and accomodates over 100 participants an hour.

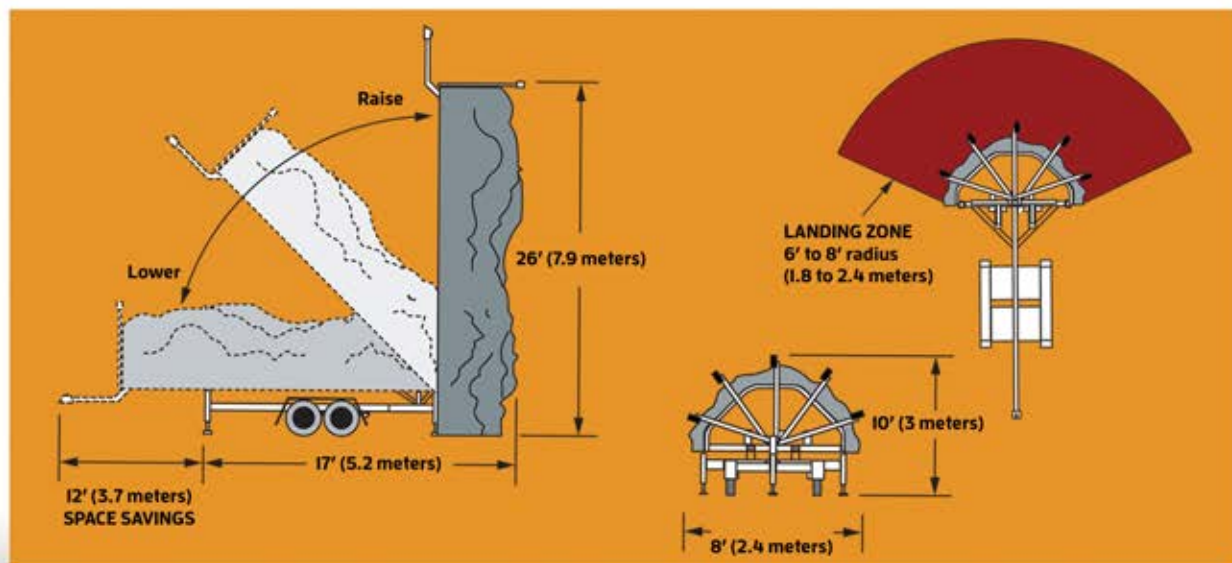

GEO WALL CLIMBING WALL

Mobile GeoWall (3 or 4 Person Climbing Wall)

A MODERN TWIST TO CLIMBING.

Weight Limit:	45-250 lbs (20-114 KG)
Climbers:	3 or 4 climbers
Height:	26' (7.9 Meters)
Surface Area:	390 SF (36.1 Meters)
Travel Height:	9'2" (2.8 Meters)
Travel Width:	8'0" (2.4 Meters)
Dry Weight:	4,400 lbs MW3 Version (2,000 KG) 4,800 lbs MW4 Version (2,182 KG)
Brake:	Electric 12 Volt
Auto-belays™ :	Fully Redundant

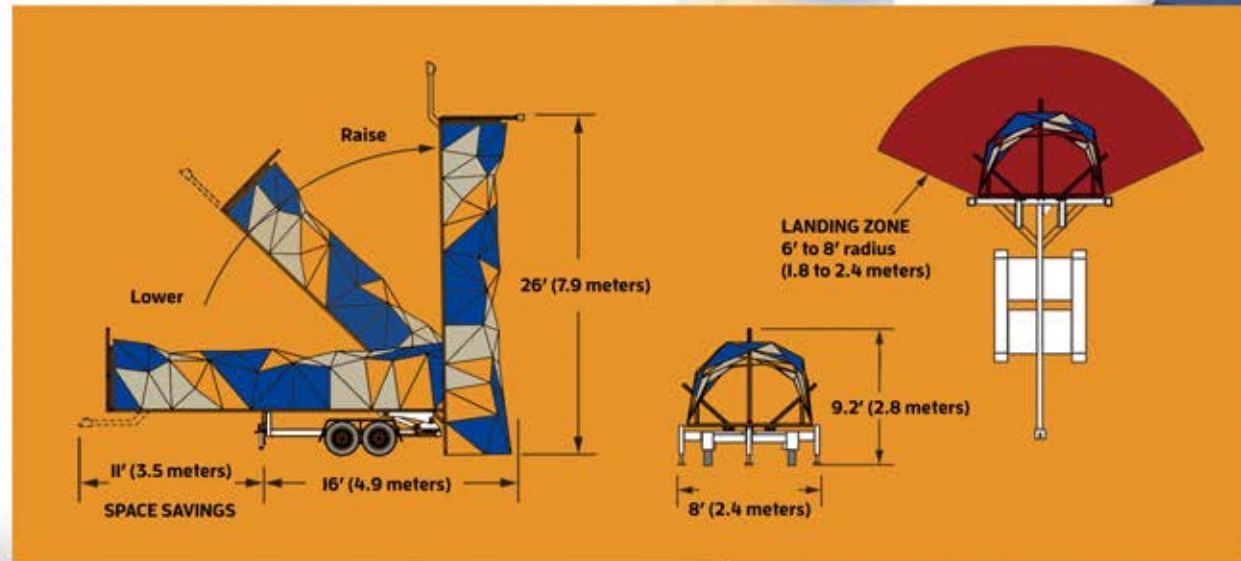

EVEREST CLIMBING WALL

Mobile Everest (5 Person Climbing Wall)

FOR THOSE WHO MUST HAVE THE TALLEST.

- Weight Limit: 45-250 lbs (20-114 KG)
- Climbers: 5 climbers
- Height: 35' (10.7 Meters)
- Surface Area: 500 SF (153 Meters)
- Travel Height: 10'0" (3 Meters)
- Travel Width: 8' (2.4 Meters)
- Dry Weight: 6,000 lbs (2,727 KG)
- Brake: Electric 12 Volt
- Auto-belays™ : Fully Redundant

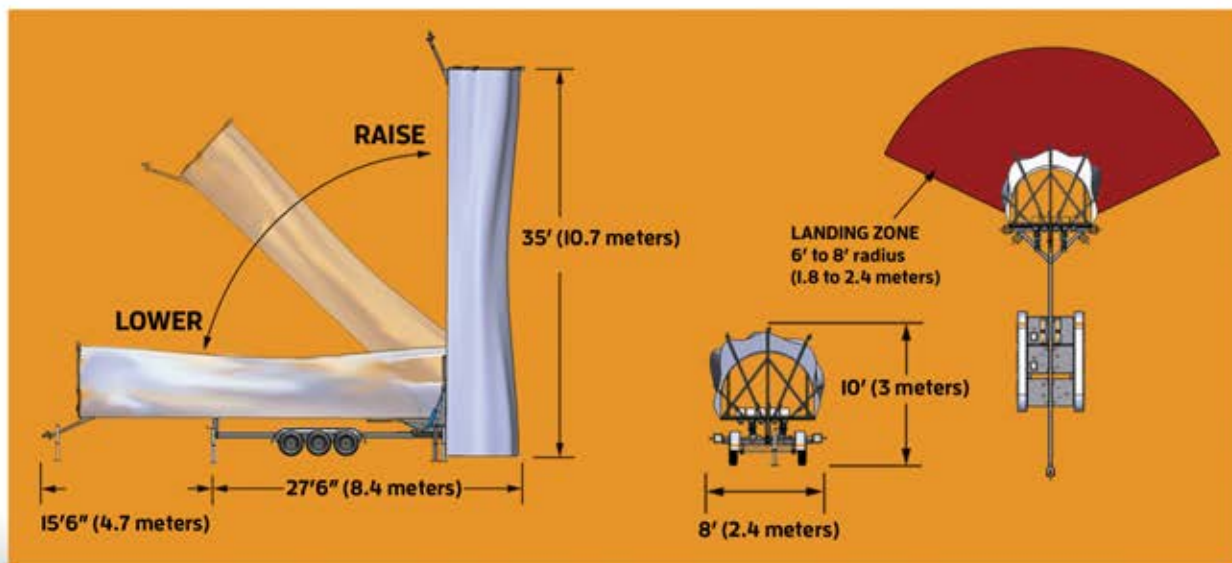

SPACE SAVER TRAILER

The patented Space Saver Trailer™, exclusively provided by Extreme Legacy, is used on every mobile climbing wall sold today. The trailer design shortens the footprint needed for operation. With a Space Saver Trailer™ most of the mobile climbing walls can operate within 200 SQ FT (61 Meters SQ). Our products are designed using aeronautical principles, making Extreme Legacy's products the lightest and strongest in the industry. The lightweight trailer design is fuel efficient. All Extreme Legacy's Space Saver Trailers™ meet ASTM, and other industry standards. The Space Saver Trailers™ are used by professional operators worldwide.



AUTO-BELAY SYSTEM

You're in good hands—or rather, in the care of top-tier auto-belay devices! Let our machine take over while you kick back, as it handles the work of a belayer for you. Efficient, reliable, and always on time, our auto-belays come standard with every mobile climbing wall we sell. If you're aiming to streamline your staffing and safely replace manual belaying, look no further. Extreme Legacy's auto-belays are the only fully redundant systems available, and they've earned the prestigious "Best Technology Applied" award from industry leaders at IAAPA. This is the safest auto-belay system on the market. Our devices never get distracted, never take breaks, and never get tired. After each climb, the system gradually lowers participants back to the ground, ensuring safety every time. Auto-belays are the perfect fit for rope courses, climbing gyms, fitness centers, and even search-and-rescue operations. They meet all major safety standards, including ASTM.





WANT TO KNOW WHAT IT FEELS LIKE TO FLY?

Take flight on the best air jumper on the market.



We provide the engineering geek, marketing sleek and business sales success all in one! Our products are designed by a team of the most talented aeronautical and mechanical engineers, business professionals, and marketing gurus in the world. Extreme Legacy only uses the best materials available in the production process of every Extreme Air.

**WE ARE
YOUR ADVENTURE
ENTHUSIASTS**



As Shown: Mobile Extreme Air™ In Line Jumper

EXTREME AIR JUMPER

There are jumpers and then there are Extreme Legacy jumpers. The Extreme Air™ jumper systems use patented fiberglass pole technology, allowing participants to soar up to 25 feet in the air! With set-up times of just 20 minutes you will be spending more time making money and less time battling set-up. The Extreme Air™ jumper systems are the only kind on the market to use wireless remote technology, removing the amount of staff needed. With innovative technology, design and other state-of-the-art components, the cost of ownership is just a fraction of all other air jumper systems on the market. The dynamic fiberglass poles, "Flex Pole Technology™," supports a wide range of weights, eliminating the mounds of harness sizes needed. With faster cycle times, less staff and less maintenance costs, why would you jump anywhere else?



FLYER HARNESS

Faster, Safer, Better.



The breakthrough features on the new Flyer Harness™ makes it the most comfortable and universal harness on the market! With wide and padded leg straps, a fully adjustable waist belt and industry standard buckles, this is the jumper harness of choice! Junior sizes are also available for small children. Harnesses are compatible with any jumper system!



MOBILE EXTREME AIR

Mobile Extreme Air (4 Person Jumper)

SOAR TO GREAT HEIGHTS.

Weight Limit:	45-250 lbs (20-114 KG)
Jumpers:	4 Jumpers
Height:	Up to 25' (7.6 Meters)
Surface Area:	1350 SF (441.60 Meters)
Travel Height:	4'0" (1.2 Meters)
Travel Width:	90" (2.3 Meters)
Dry Weight:	3,500 lbs (1,588 KG)
Power:	110V AC 60HZ (15 AMPS)
Poles:	Flex Pole Technology

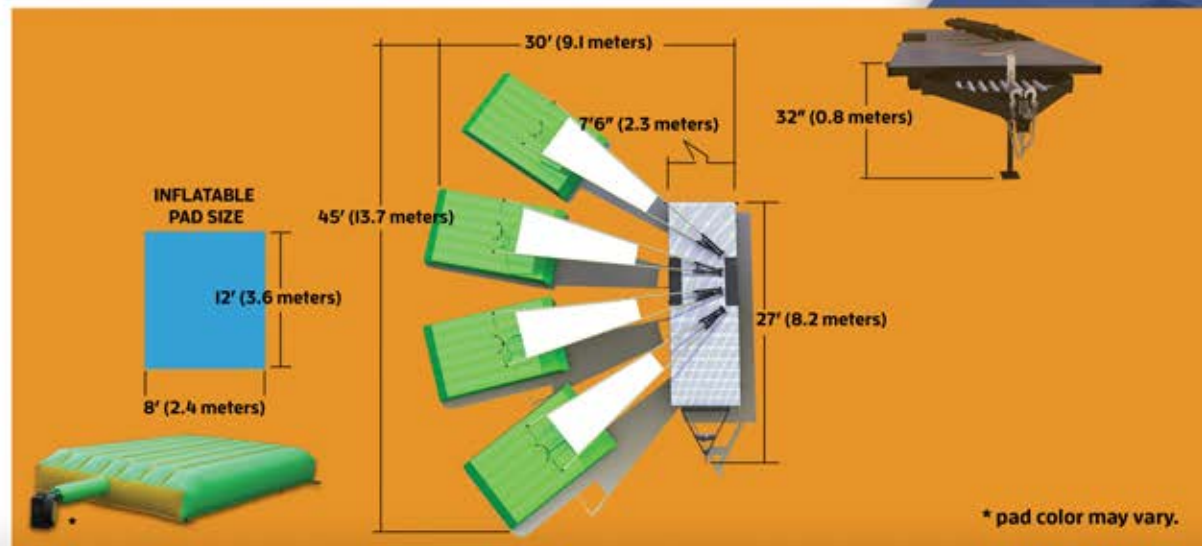

WHAT'S YOUR HIDDEN SUPER POWER?

As seen on the:

Travel
CHANNEL

MOBILE FLY WIRE ZIPLINE

The Fly Wire zipline has gained traction and notoriety as the "Best Major Theme Park Ride" – one of the highest industry honors – for its brilliant design and savvy configuration. A spiral staircase leads to a zipline tower which allows two riders at the same time on two lines. This zipline configuration is the safest and fastest in the world.

Going mobile has many advantages and can benefit your business and promotional needs. All of Extreme Legacy's mobile attractions setup quickly, and can be easily relocated around your property or other destinations. The flexibility of our exciting mobile adventure rides allows you to reconfigure your adventure experience at any time.





The award winning Fly Wire™ Zipline, winner of “Best Major Theme Park Ride” and “Best Technology Applied” at IAAPA, provides thrill seekers the ultimate rush of zip-lining across the sky up to 300 feet on a mobile zipline - the length of an entire football field. Thrill seekers can zipline even longer on our stationary models. Offering the fastest cycle times on the market to serve up to 90 riders an hour, there is no other zipline product in the world that can compete with the Fly Wire’s™ ease of set-up and completely controlled method of keeping zip-liners soaring with confidence. The Fly Wire™ is your amusement zipline solution! With superior engineering and the patent pending Decelinator™ safety system why would you zipline anywhere else? Every mobile and stationary exceeds ASTM and other industry standards. Extreme Legacy offers a fast, fun and safe zipline ride every time!

We provide the engineering geek, marketing sleek and business sales success all in one! Our products are designed by a team of the most talented aeronautical and mechanical engineers, business professionals, and marketing gurus in the world. Extreme Legacy only uses the best materials available in the production process of every Fly Wire™ Zipline.

**WE ARE
YOUR ADVENTURE
ENTHUSIASTS**



MONDAYS SEPT FOX

MOBILE FLY WIRE ZIPLINE

Channel your inner superhero and zip into profit with the mobile "Fly Wire™" zipline by Extreme Legacy. Thrill seekers of all ages will be lining up to experience the ultimate rush of ziplining across the length of a football field (up to 300 feet*). Zipline at serious speeds on the awarded "Best Major Theme Park Ride." Soar at 21 MPH with two people at the same time! The Fly Wire™ is the zipline solution for the amusement industry that is looking for quick cycle times, safety and low staffing. No other zipline in the world can compete with the Fly Wire's™ quick cycle times. Zip up to 90 people an hour! The mobile Fly Wire™ is easy to setup. Extreme Legacy's zipline has a completely controlled method of keeping zip-liners safely off the ground.

*300 foot option is not included on mobile standard units.



FLY WIRE ZIPLINE



Extreme Legacy's Fly Wire™ zipline is perfect for promotions, such as tv and movie premieres. The mobile zipline can be custom themed to amplify any brand you desire!

DECELINATOR

There is safe, and then there is Extreme Legacy safe. The Fly Wire™ is the only zipline of its kind using the safest decelerator on the market, the Decelinator™, a proprietary device that fully lowers zip-liners and everyday superheroes safely to the ground. The hydraulically activated Decelinator™ raises up in the air, keeping zip liners safely off the landing area. Once the zipline trolley descends into a "Power Pack," a variable rate shock, the zip-liners are safely slowed down at the end of each ride. When the zip liners are stopped, they are hydraulically lowered safely to the landing area. The Decelinator™ also controls the zipline tower's exit doors, preventing them from opening until the zipline is ready for operation. No other zipline in the world offers these safety features. This is one advanced, amusement zipline ride!

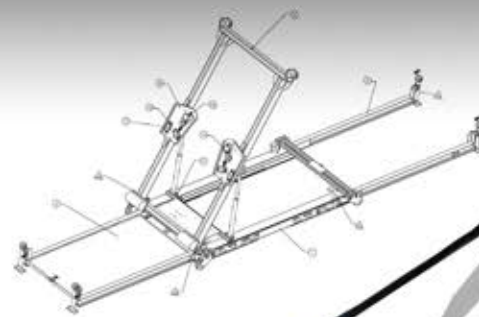

AWARDED FOR
TECHNOLOGY
AT IAAPA!



1. Tow to location.



3. Pull forward & raise tower.

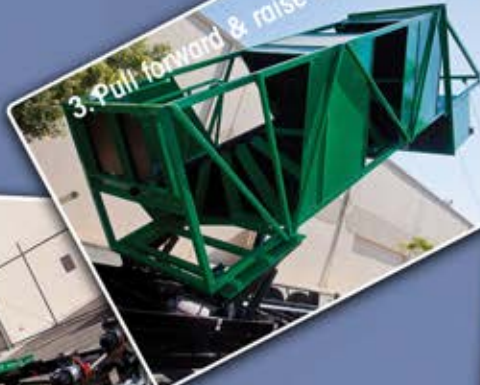

2. Drop integrated
Decelinator™ from trailer.



4. Walk up staircase.



5. Zip across a
waterpark!



MOBILE FLY WIRE ZIPLINE

Mobile Fly Wire Zipline

LONGEST MOBILE ZIPLINE.

Weight Limit:	45-250 lbs (20-114 KG)
Operating Height:	30' (9.15 Meters)
Operating Width:	10' (3.05 Meters)
Operating Length:	*Up to 300' (91.50 Meters)
Dry Weight:	10,000 lbs (4,545 KG)
Brake:	Tandem Axle, Electric
Decelerator:	Decelinator™
Counter Weight:	3,500 lbs (1,591 KG)

*300' is optional.

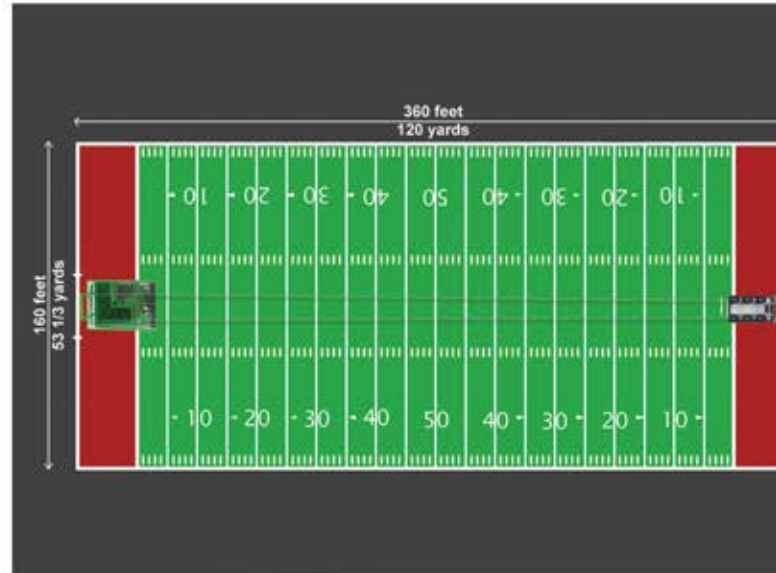

This is the amusement zipline solution. With adjustable zip length from 100 to 300 feet on our mobile configuration, set-up time in just minutes and the fastest cycle times on the market why would you zipline anywhere else?

Yes, you can zipline an entire football field length with our mobile Fly Wire™, the longest mobile zipline on the market!

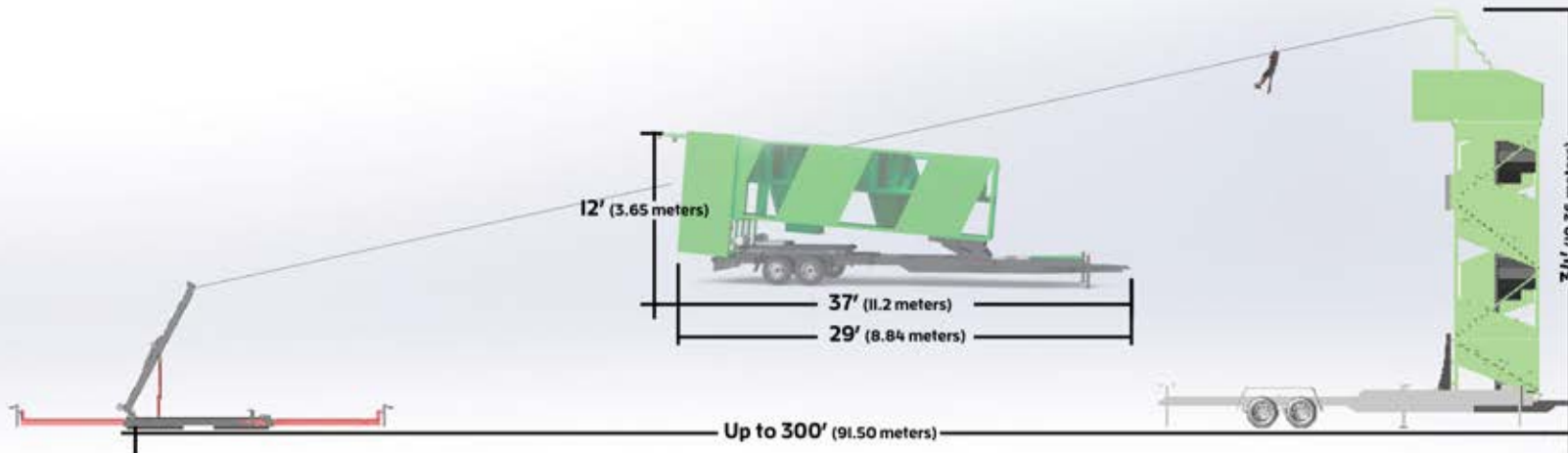

FLX SHADE

Easy Aid To Shade





FLX Shade™ system above a queuing area.



FLX SHADE

Easy Aid To Shade

The patent pending FLX Shade™ system uses our patented flex rod technology. The flex rod provides the load tension, minimizing all the cumbersome hardware needed to tighten traditional sail shades. FLX Shades™ are configurable by length, pitch and height as well as come in over 30 colors.

We can create shade almost anywhere. The FLX Shade™ system can easily create shade for your guests to enjoy at theme parks, queuing areas, commercial spaces, resorts, sport centers, outdoor museums to everything else in between. The FLX Shade™ system can withstand high wind loads up to 70 MPH and harsh, outdoor weather. Our above ground anchor options make the FLX Shade™ installation a breeze! We also offer the best warranty options on the market, up to 10 years on Sails, 10 years on structure and a limited 10 years on the flex rods.



FLX SHADE™ - Easy Aid To Shade

The FLX Shade™ system offers unlimited layouts, easily blending in with the natural environment, while also providing maximum shade potential. The small flex poles, just 2 ½ inches in diameter, minimize the amount of structure needed. Up to 50% less in structure is used to install the FLX Shade. Create aesthetically pleasing shade that provides focal points on designated areas, not blockades, throughout a park.



FLX SHADE™ - Optional Above Ground Mounts

Above ground options available with the FLX Shade™ mounts. FLX Shade™ mounts designed to easily install into concrete with expansion bolts (comes included with hardware). Above ground option is designed to not impact existing infrastructure below ground, such as electrical and water lines. Flex poles easily slide into mounts for shade set up.

Sample Layout

FLX SHADE

The anatomy of great shade

FLEX ROD TECHNOLOGY

The patented flex rod technology provides the load tension, minimizing all the cumbersome hardware typically needed to tighten the sail shades.

ADJUSTABLE CLAMP AND CHAIN LINK

The included clamp and chain link kit can be adjusted to easily distance the sails and set the desired angles with the flex rods.

END CAPS

The flex rods come fully equipped with precision endcaps.

SAILS

The FLX Shade™ system can utilize various sail shapes, sizes and grades. Sails are available in over 30 colors, including screen printing.

ABOVE GROUND MOUNTS

The FLX Shade™ system offers optional above ground steel mounts. The steel mounts can be easily installed above concrete with anchor bolts (included). Flex poles can easily slide out of the mounts when not in use.



FLX SHADE™ - Standard Sizes

The FLX Shade™ offers 4 standard sail sizes, with custom options available.

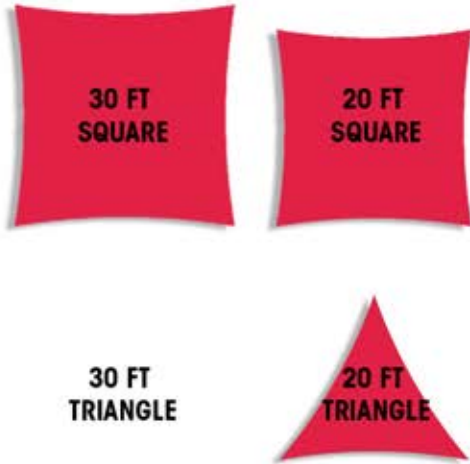

FLX SHADE™ - Sail Colors

The FLX Shade™ offers over 30 sail colors, using the highest grade materials on the market. The sail material is a perfect balance between weight and UV protection. It is also slightly stretchable, making it tear, rot and fray resistant. The sails come with a standard 10-year warranty against UV degradation and are 100% recyclable. Here are just some of the vibrant colors to select from:



FLX SHADE™ - Technical Data

- Warranty: 10 years on sails, structure and flex poles.
- Flooring Types: Concrete, steel and other surfaces after evaluation.
- Below Ground Install: 3 feet for steel sleeve inserts.
- Above Ground: 5 inches minimum of concrete thickness for above ground mounts.
- Max Pole Lengths Included: 12 feet.
- How Many Sails To A Single Pole: 2 sail corners per pole.
- Max Wind Load: 70 MPH (112 KM/H).
- Max Span For Sails: 30 feet.
- Pole Distances For Sails: 12 inches at each corner.
- Flex Pole diameter: 2 ½ inches.
- Installation: We offer installation or the sails can be self-installed.

HIGHLIGHTED FLX SHADE LOCATIONS



HIGHLIGHTED FLX SHADE LOCATIONS

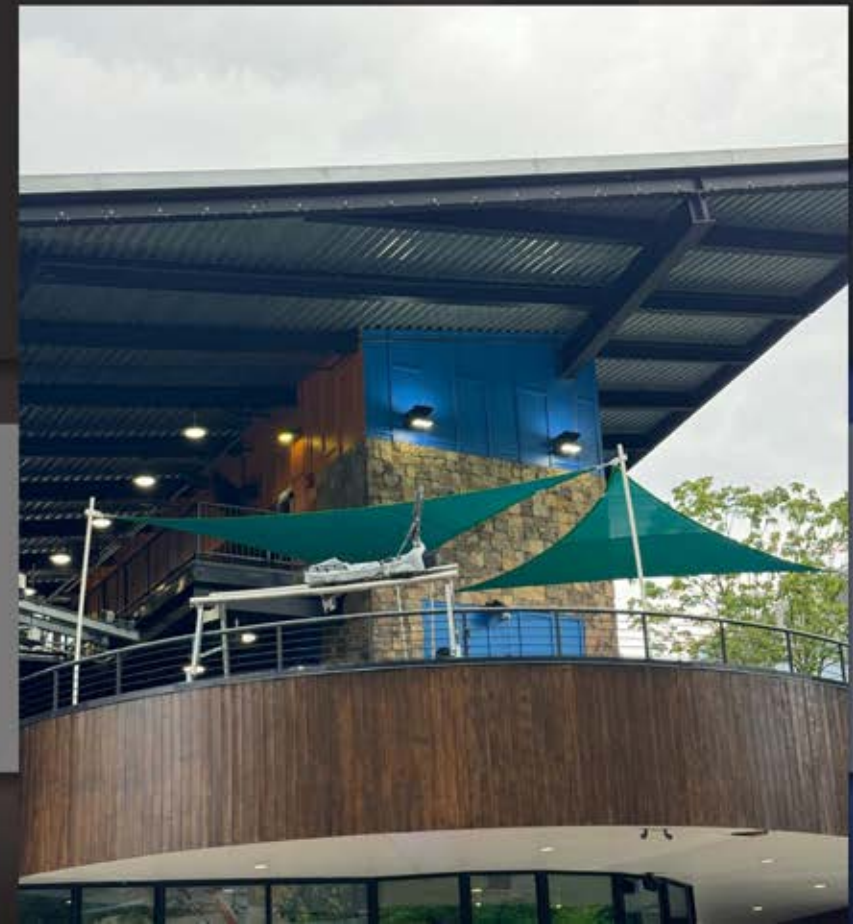

FUTURE ATTRACTIONS



Extreme Legacy is known for designing the future in entertainment. Combining our expertise in engineering design services and passion in the amusement industry, we constantly are working on new attractions and also enhancing existing ones. Here are a few attractions we can make reality:

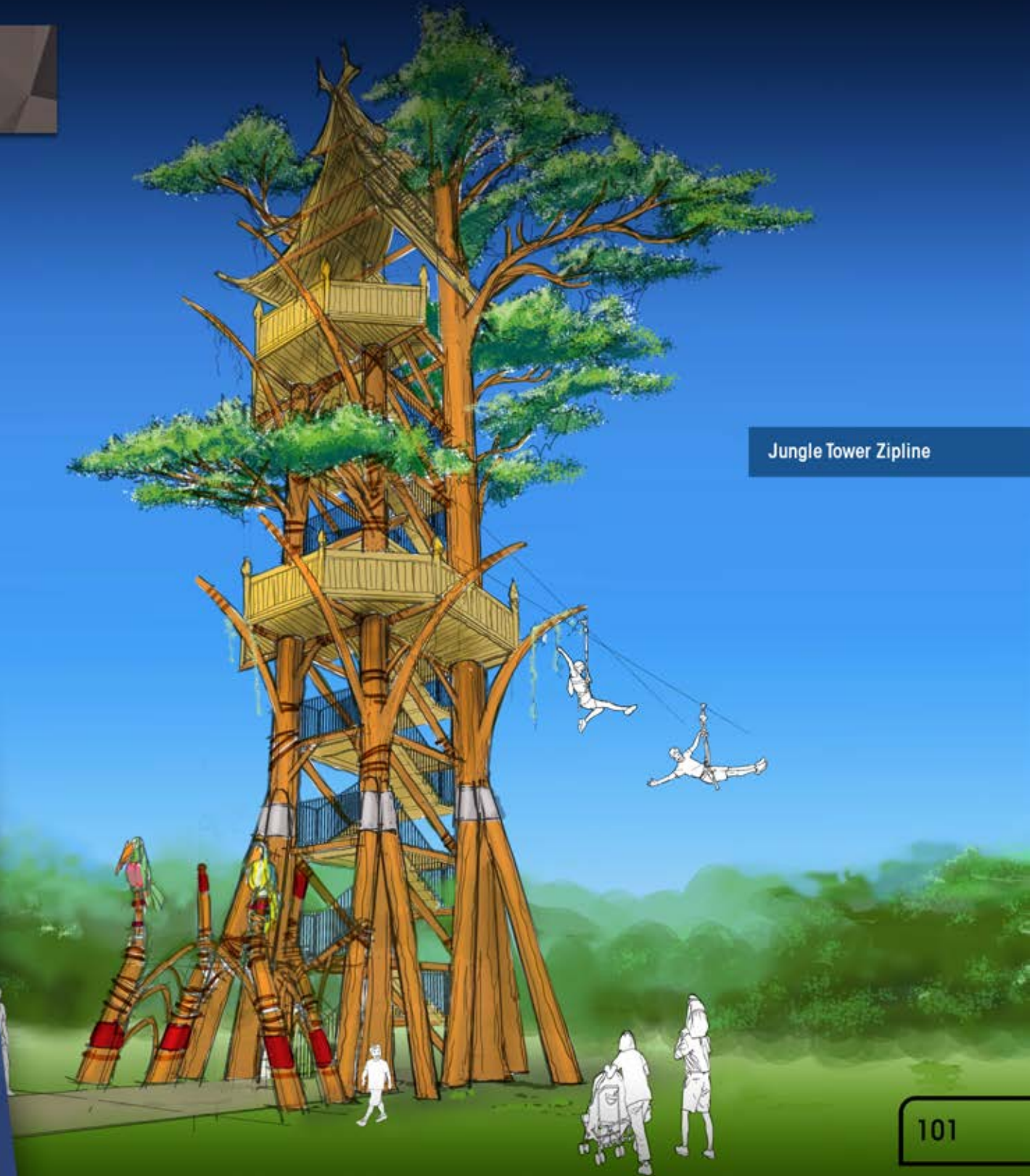

Jungle Tower Zipline

FUNICULAR



Our version of the funicular utilizes a track system that requires low power requirements. The track system can also be designed to adjust the speed and experience of the funicular. Our cart system can be fully themed, include onboard solar charging and other features you would expect on high-end funicular attractions. We also made our version of the funicular safer, offering multiple redundancies through the track, braking devices and cart.



Extreme Legacy's Funicular

FUNICULAR CON'T

ATTRACTION FEATURES

RIDER CAPACITY

- 14 person payload.
- Seating for 4 passengers.

SOLAR CHARGING

- Solar charging for on-board BBU (battery backup) system.

TRACK SYSTEM

- Constructed from open-over sized-galvanized medium carbon steel.
- Welded cross members to increase rigidity.
- Structural support members designed to handle additional future loading.

WHEELCHAIR ACCESS

- Doors to accommodate wheel chairs and other wide loads.

CARGO STORAGE

- Additional 200 kilograms in cargo payload.

DRIVE SYSTEM

- Eddy current magnetic braking (MBS system).
- Wireless remote control.
- Downhill power brake resistor, to increase motor brake longevity.
- 45 HP motor and high efficiency gearbox with commercial full duty motor brake.
- Heavy duty wire rope drum and pillow block bearing assembly.
- Life wire rope system with 5X factor of safety and redundant terminations.

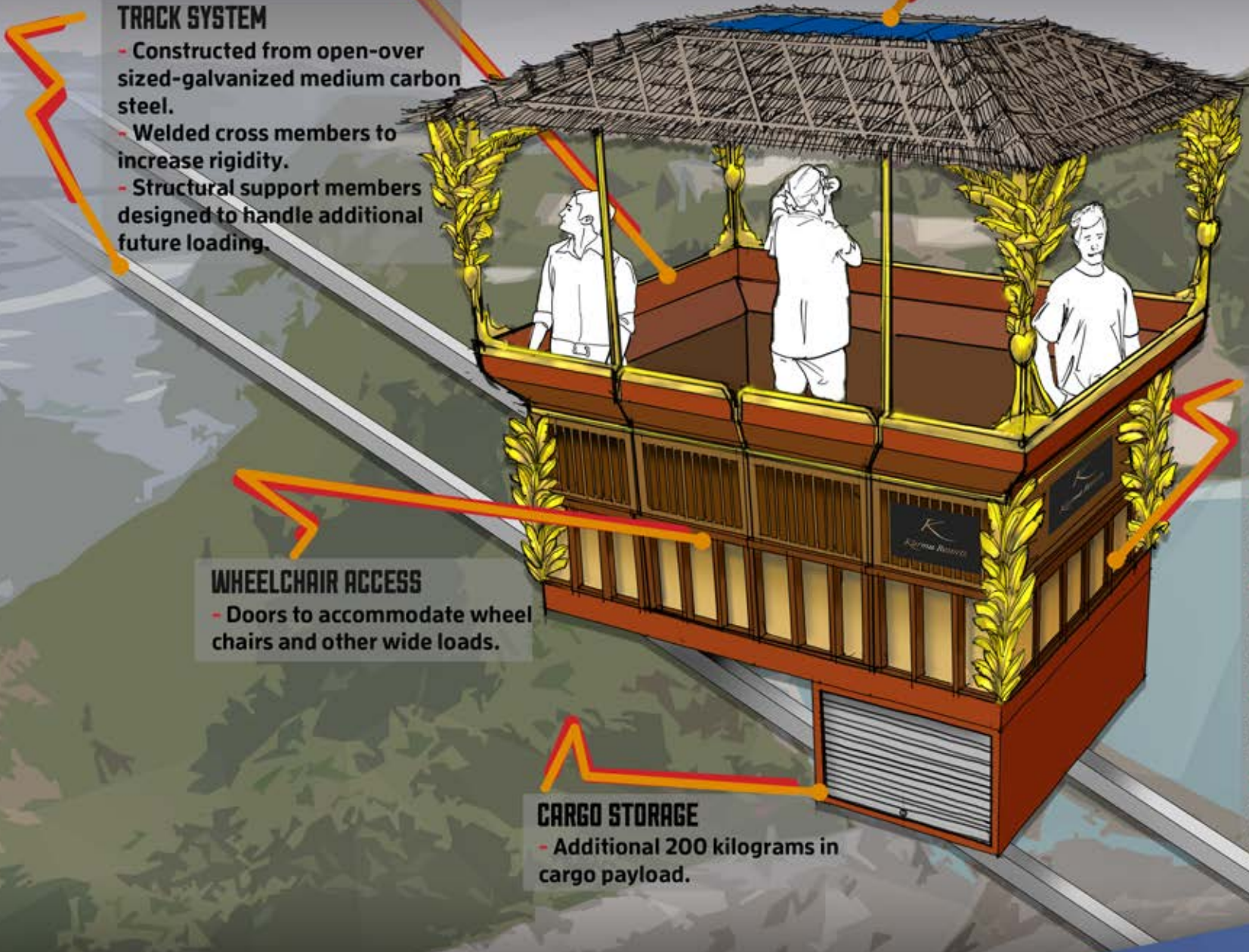

INTERACTIVE OBSERVATION TOWER

Our interactive observation tower allows participants of all ages to get a birds eye view of the surrounding below. The innovative lift system safely secures riders on the outside of a tower, which then raises them to the top for a breathtaking view. Participants can also exit at the top of the tower where optional attractions can be experienced.



EXTREME ADVENTURE TOWER

The Extreme Adventure Tower was designed to offer various adventure attractions on a single tower platform. Each level of the tower would offer various "extreme" activities such as rock climbing, ziplining, free falling and more.

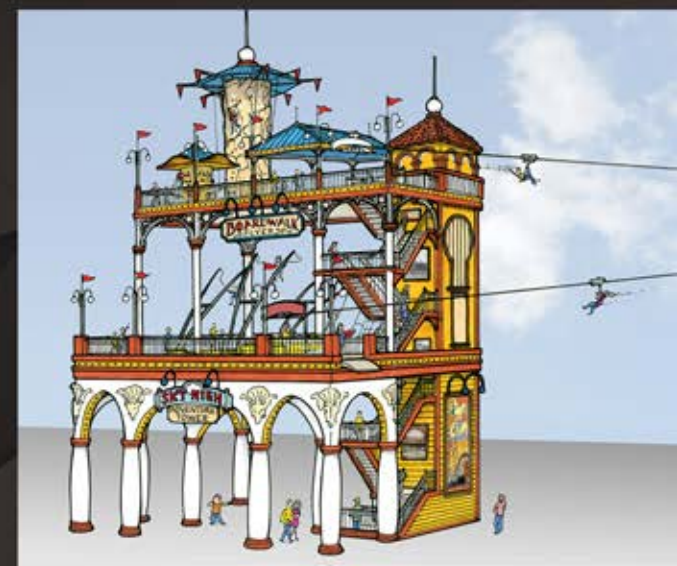

Adventure Tower Configurations

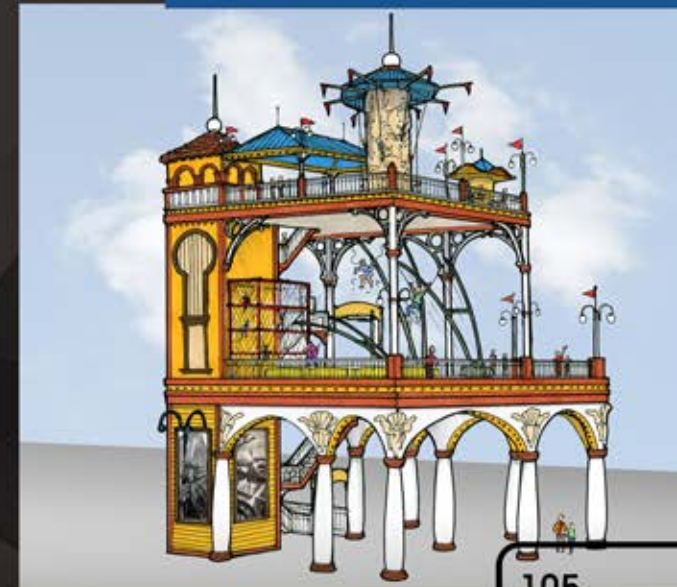

The tower design is fully flexible with theming options and a various mix of attractions to choose from. The modular design also minimizes the amount of operational space required.

Extreme Legacy
424 East Central Blvd
PO BOX 105
Orlando, FL 32801
+1.916.663.1560
info@extremelegacy.com
www.extremelegacy.com



**INVENTING
FORWARD.**



All Products Designed
and Built in the USA.